

**valveforce**™  
the power in your process



KNOWLEDGE  
EXPERTISE  
POWER  
ENERGY  
STEAM

Open up to a world of valve and system expertise

[www.valveforce.co.uk](http://www.valveforce.co.uk)



# Contents

WELCOME	3
OUR MARKETS AND INDUSTRIES	4-5
OUR EXPERTISE AND THE BENEFITS TO YOU	6-7
OUR SERVICES SUPPORT AND ON-SITE SOLUTIONS	8-9
HIGH QUALITY SERVICE AND PRODUCTS	10-11
CONTROL VALVES	12-19
ENERGY CENTRE AND STEAM SYSTEM SPECIALISTS	20-21
CONTROL VALVES	22-23
SELF ACTING REGULATORS	24-27
PIPELINE PRODUCTS	28-35
STEAM SOLUTIONS	36-37
HYGIENIC VALVES	38-39



## Welcome to Valveforce

Our business purpose is to engage with our customers, building long term trusted partnerships by providing independent expert advice and support on flow control technologies. We work together to achieve the right technical solution at the right price.

At the core of our company is an exceptional team. They are highly trained, experienced, proactive engineers, technicians and sales support staff who play a vital role in Valveforce's reputation for reliability and outstanding customer support.

We offer all the advantages of big company support and back-up, while remaining firmly focused on the virtues of close customer contact and genuine personal service.



**Marc Bozdogan**  
Managing Director

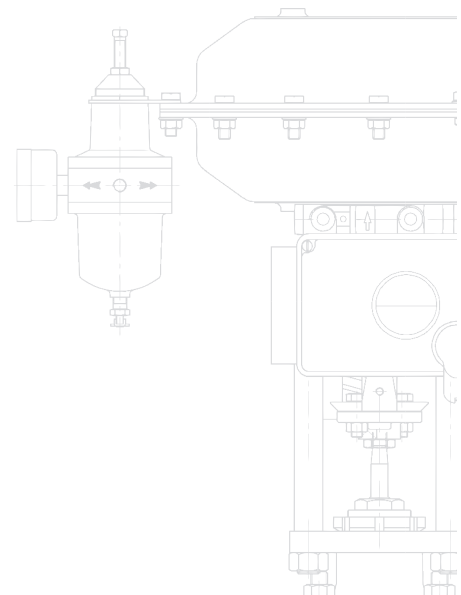



# Our markets and industries

## STEAM AND CONDENSATE



### Steam and condensate loop

We can be of benefit to you in the steam and condensate loop. We are steam system engineers who are often called upon to design, specify and supply full equipment packages. We are relied upon to give unbiased support and advice to ensure you get the right product for the right application.

## ENERGY AND POWER



### Energy centre and power generation

Our experience will bring value to your Combined Heat and Power (CHP) Cogen and Trigen plant projects. Our product ranges in this area are boiler control equipment such as level, TDS and blow down systems, pressurised deaerator plant, severe service control valves, turbine bypass valves and de-superheating stations.

## WATER AND WASTE



### Water and waste water treatment

An increasing number of our clients and technology providers are turning to steam for their heating requirements. This has been driven by the requirements for better outputs, lower maintenance and lower nitrate levels. Here, we supply steam and condensate systems, process valve packages and heat transfer skids.





### Working throughout industry

As detailed steam and process control specialists we are able to work closely with our customers and use our experience and wealth of expertise to help solve critical issues in many areas throughout industry.

#### FOOD AND BEVERAGE



##### Food and beverage industry

By working with engineers we ensure plant is optimised with efficient use of steam and hot water. We design and supply steam distribution systems, hot water heat exchanger packages, temperature control loops and steam injection sets. We also supply a full line of sanitary process valves, steam traps and clean steam filters.

#### HEATING AND COOLING

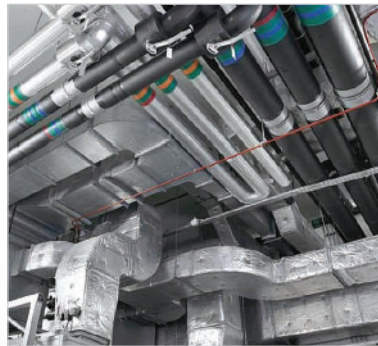

##### Heating, ventilating and air conditioning

This is a core business for us. We work with building services engineers and facilities management teams to supply valves. These include temperature control, self acting control, butterfly, ball valves, commissioning and metering sets which are used throughout the CWS, MPHw, HPHw and steam distribution plant.

#### PAPER AND PULP



##### Paper and pulp

We engineer and supply various rotary control valves such as high performance butterfly and segmented ball valves along with linear knife gate valves often with intelligent controls to optimise performance. On corrugating machines we provide the steam temperature control valves along with the condensate recovery systems and steam traps.

# Our expertise and the benefits to you

## Our capabilities

From the moment you first contact us at Valveforce you benefit from industry leading expertise gained over many years at the forefront of steam and process valve technology.

We are committed to providing the industry with the newest technology, consistent high quality, outstanding reliability and higher levels of performance.

## Valveforce has the complete portfolio

- Steam system specialists
- Steam system layout engineering and design
- Energy centre feed water, blow down and heat recovery
- Steam controls, steam conditioning and condensate return
  
- Control valve experts
- High pressure energy control valves
- Linear globe control valves
- Rotary process control valves
  
- Pipeline ancillary packages
- Gate, globe and check valves
- Quarter turn butterfly and ball valves
- Strainers, steam traps and sight glasses







## Reasons to work with us

Independent research amongst our customers highlighted our independent and impartial technical advice backed up by a high level of customer service and support as the two most important factors in choosing to do business with us.

### Delivering true value

Whether you need to reduce your project capital, save your maintenance budgets or simply get a very competitive valve proposal our detailed pricing structure will provide the solution.

### Saving time and effort

Let our independent engineers carry out the work for you. We will design, specify and supply all of your valve and process control requirements, allowing you to concentrate on your core business.

### Giving peace of mind

Our extensive industrial experience and detailed application knowledge enables us to understand your process problems. We then draw on this knowledge to supply a system you can trust.

### Right solution, right price

Our manufacturer neutrality enables us to design and specify the most cost effective solution for your application.

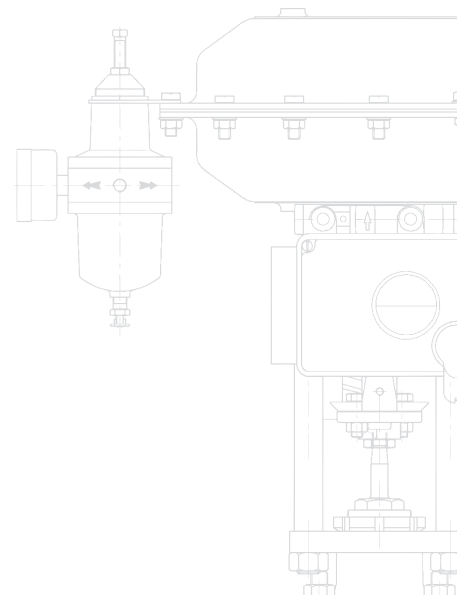



# Our services

## support and on-site solutions

In recent years our customers' requirements have changed. This is due to the significant loss of engineering expertise and the manpower to carry out the detailed engineering work. At Valveforce we are relied upon more and more as a specialist extension to our customers' team, providing valuable support services where required.

With the manpower and core competencies we have available our engineers will work with you to improve, monitor and maintain your plant and your processes. Our comprehensive range of service products are specifically tailored to meet our customers' requirements.

### Specification and design

#### Designing the right solution

Our team will walk the plant with you to assess your requirements. We can then apply our extensive valve and associated technology expertise to offer you a structured independent recommendation for the improvement of your process efficiency, productivity and plant effectiveness.

We will look at ways to:

- Reduce energy consumption and recover valuable heat that can be lost from your process
- Ensure steam plant and steam traps are surveyed and working efficiently
- Work alongside you to ensure value for money and improved return on your plant investment

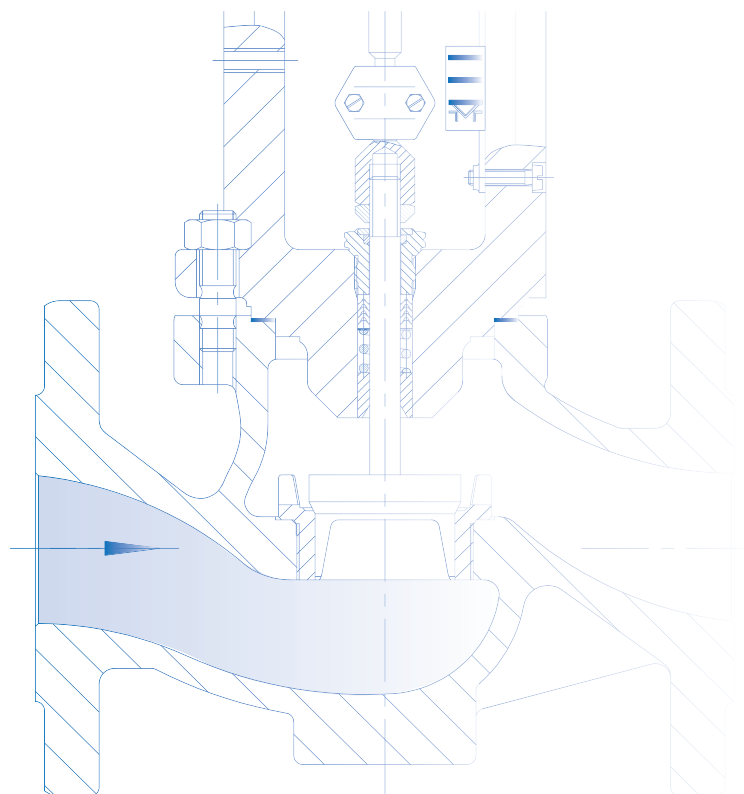

Rely on Valveforce to design, specify and supply your full equipment package. You will receive independent support and expert advice to guarantee the right product for your application.



“Enjoy the peace of mind that your process valves are in the hands of experts, and working to full capacity”

## Maintenance and service

### Increasing your uptime

Our technical maintenance service will ensure that your products are regularly tested and maintained. We will leave you with the peace of mind that your systems are working as efficiently and effectively as possible. We will also help to protect you from plant failure and ensure that you are compliant with all personal safety and environmental policies.

You will benefit from:

- Control valve servicing and testing
- Isolating valve overhaul and repair
- On site test and calibration
- In-situ valve testing and reconditioning
- Annual safety valve servicing agreements
- Steam and energy surveys

## Installation and commissioning

### Turnkey projects delivered on time

As relied upon experienced engineers, we are able to carry out the complete turnkey installation through to commissioning and acceptance sign off.

The installation will be carried out by experienced specialists to avoid any post installation delays. Our installations are specifically project managed to ensure tight project time scales are met and the contract is delivered on time and on budget.

Our complete services includes:

- Project management
- Delivery scheduling, off-loading and positioning
- Mechanical and electrical installation
- Thermal insulation and cladding
- Calibration and commissioning
- System test and system integration
- Documentation and acceptance sign off

These projects and products can then be supported by our aftersales team who will organise support services such as maintenance contracts, performance reviews and reporting if required.



# High quality service and products

Our expertise in flow control and in-depth knowledge of steam and process system design has allowed us to develop a portfolio of high quality products capable of satisfying some of the most demanding applications in industry today.

## The range

At Valveforce we are proud to be able to offer our customers solutions to some of their most complex requirements, from bespoke energy centre design and supply through to detailed design of control valves for specific applications. Many of our systems have been custom designed to overcome the most stringent flow criteria. We are convinced that once you have browsed through our product range you will be assured of our expertise and impressed by our range.

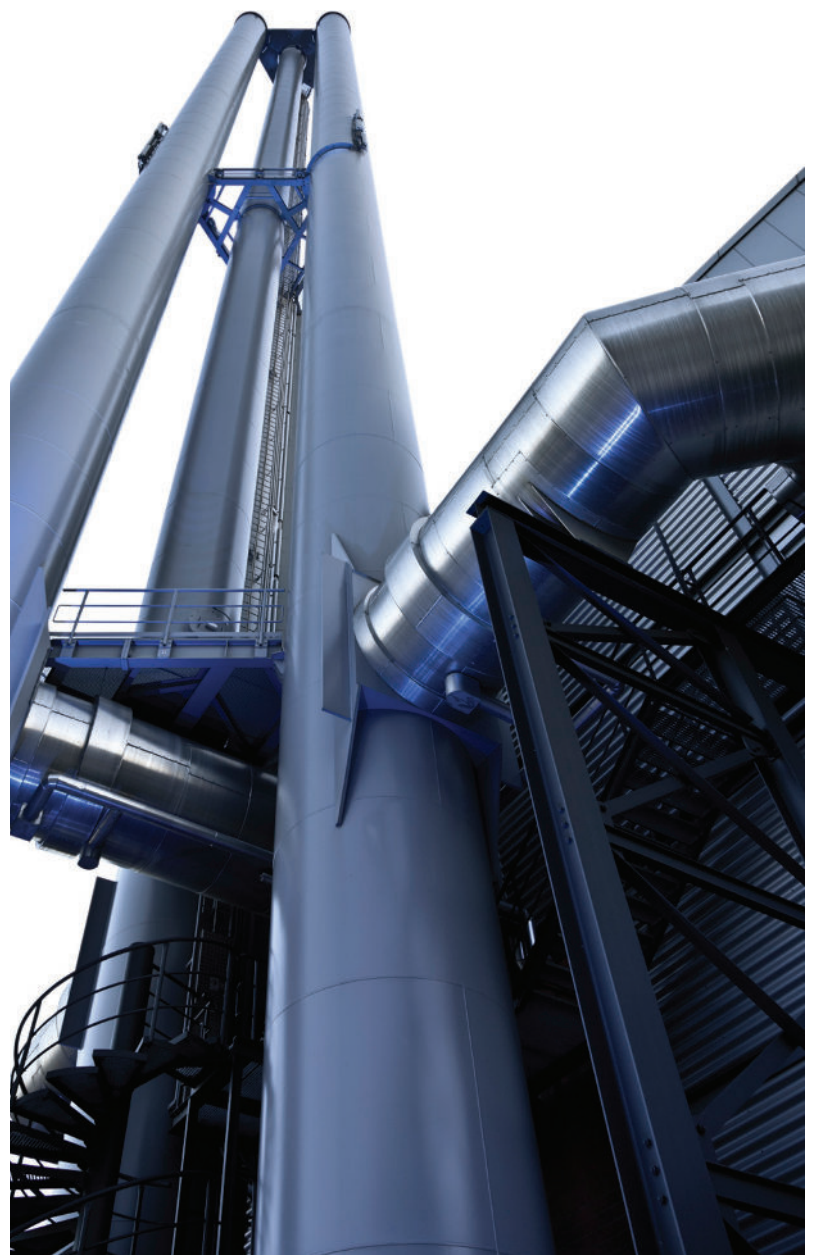
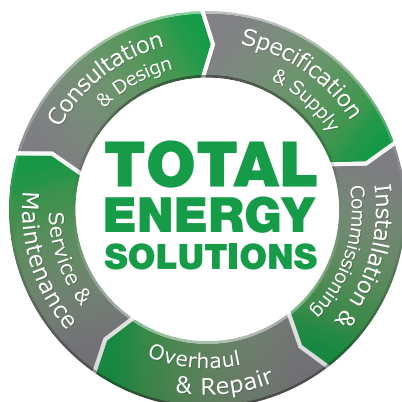





### Energy sector

Energy applications provide the most challenging demands on flow control systems and management. Poor control of your service fluid results in heat losses that can impact badly on a company's business.

Our understanding of application specific demands across the steam, hot water and thermal oil sectors means that we can get to the core of your problems and provide a solution.

### Process sector

In the process sector rotary valves are ideal for on/off applications and are used extensively across the industry for their low pressure drop characteristics and convenience.

Our complete range is different; offering you the ability to control your flow. Our high performance butterfly valves and segmented ball valves exceed the inherent design limitations of standard rotary valves.

These valves offer the increased precision necessary for accurate flow control together with the more traditional advantages that rotary valves have always offered the process industry.

Our dedication to this sector is further enhanced by our sanitary valve range. We will specify valve packages certified for your application here and, of course, since this is Valveforce, you will find hygienic flow control solutions in this range.

### The complete package

No matter what your company requires we have a solution fit for you. We stock a wide range of pipeline ancillaries to keep your operations functioning smoothly.

From heat exchangers to steam monitoring you will find us knowledgeable, keen to help and well stocked. It makes sense, energy and process engineering is our passion.

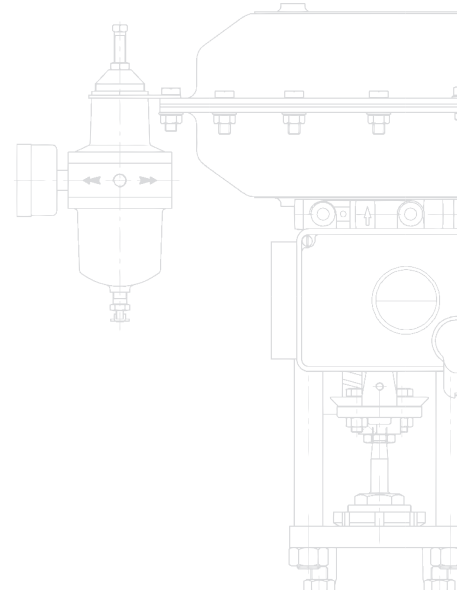

## CONTROL VALVES : High Pressure

Control of steam and water in power generation is critical to ensure the safe and efficient operation of the energy centre. Valveforce design and supply energy and severe service control valves which are used for steam and water applications such as steam let down stations, de-superheater control valves, feed water control valves, turbine bypass and condenser dump valves.



### High pressure two way pneumatic valves

- Straight through globe style design with precision cast bodies for maximum capacity
- Special design to handle a wide range of fluids such as water, thermal oil, steam, nitrogen and natural gases
- Optimised modular construction for quick change and ease of maintenance
- Large range of actuation forces available to meet most services and applications



**Mixing and diverting valves**

- Resilient construction for severe service applications
- Integral pilot valve counteracts excessive back pressure
- Double and triple cage options allow for maximum protection against cavitation
- Solid valve stem eliminating issues with hollow stem designs



**Severe duty valves**

- Maximum pressures of 250 bar with extreme pressure drop designs.
- Applications include turbine bypass, let down and de-superheating stations
- High structural integrity with thick cross sectional area
- Fully guided plug to reduce wear and increase life

Quality at competitive prices and short lead times

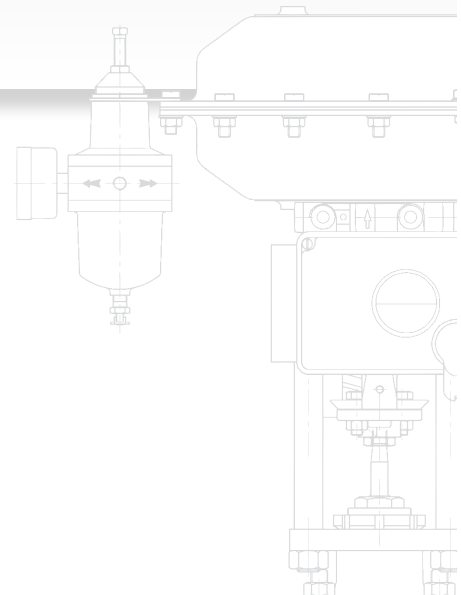



## CONTROL VALVES : Linear Pneumatic

At Valveforce we have the capabilities to help process plants with their most demanding control valve problems. Whether you need to find a cost effective control valve for cooling water service, or a stainless steel globe valve for your aggressive or pure processes.

We will be able to match your needs with the correctly specified valve with a very short lead time and quick delivery.

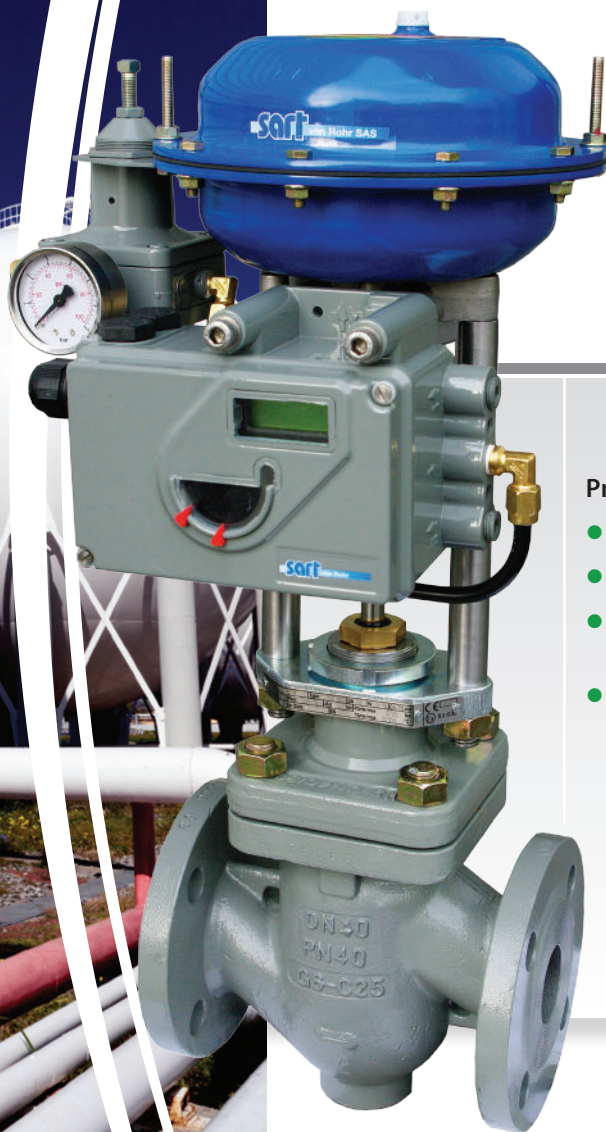

### Pneumatic control valve range

- All valves conform to DIN and ANSI standards
- Available in a full range of materials and sizes
- A well specified range of seat sizes and designs to suit most applications
- Comprehensive range in stock, ready for assembly and dispatch



### Mixing and diverting valves

- For use in hot water and thermal oil systems to maintain constant fluid temperature supply
- Excellent control guaranteed by finely engineered three port junction and plug
- Double guided stem and plug for improved life
- Rugged in design and construction for minimal maintenance



### Two way linear pneumatic valves

- Special design to handle a wide range of fluids such as water, thermal oil, steam, nitrogen and natural gases
- Modular construction for ease of interchange and quick assembly
- Large range limit switches and solenoid valves



### Process control and sensors

- A full range of process controllers and transducers are available to make a full control loop

Valve Express service available

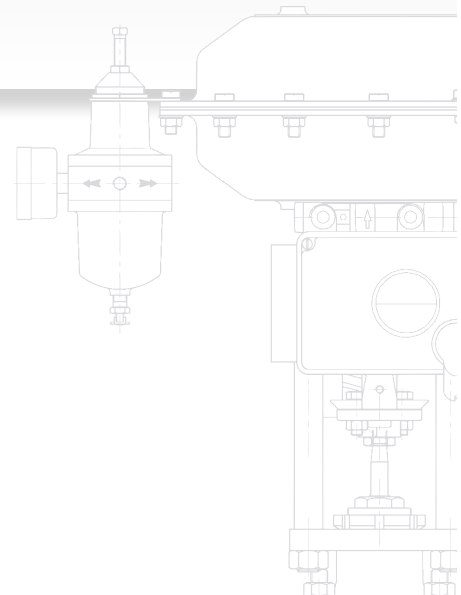

## CONTROL VALVES : Linear Electric

Our comprehensive range of electrically actuated globe control valves covers a full range of applications such as modulating, mixing and diverting. The globe valve body can be combined with various electric actuators from leading manufacturers to ensure site continuity and higher forces that are often required.



### Globe control valves

- Design to handle a wide range of fluids such as water, thermal oil, steam, nitrogen and natural gases
- Optimised modular construction for repair and application requirements
- Large range of actuation forces available to meet most services
- Supported by knowledgeable and experienced design engineers







## Electric control valves

- For applications where electric actuation is advantageous
- Quick acting electrical actuators
- Bellows sealed option for zero emissions
- Trim designs to ensure accurate control and shut off



## Heavy duty electric control valves

- Flexible manufacturing to accommodate site standard actuation
- Up to DN300 in 2 and 3 way design
- Allows for remote control by handset
- Fail safe option in the event of power failure

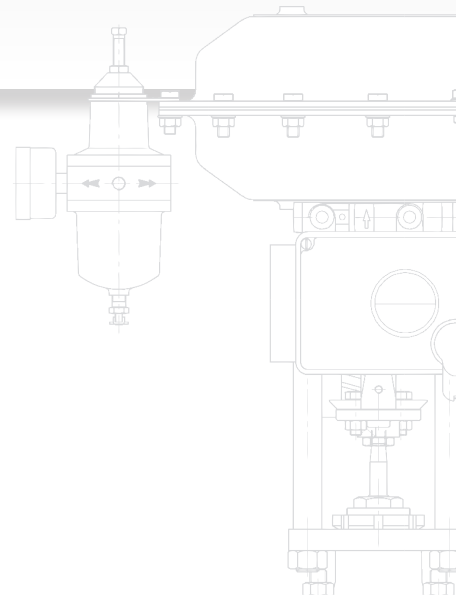

## CONTROL VALVES : Segmented Ball Valves

High capacity, excellent tightness and free flow. These words aptly describe some of the superior properties of our segmented ball valves. The ball segment valves have been designed to fulfil the strictest requirements of the process industry for the control valves used.

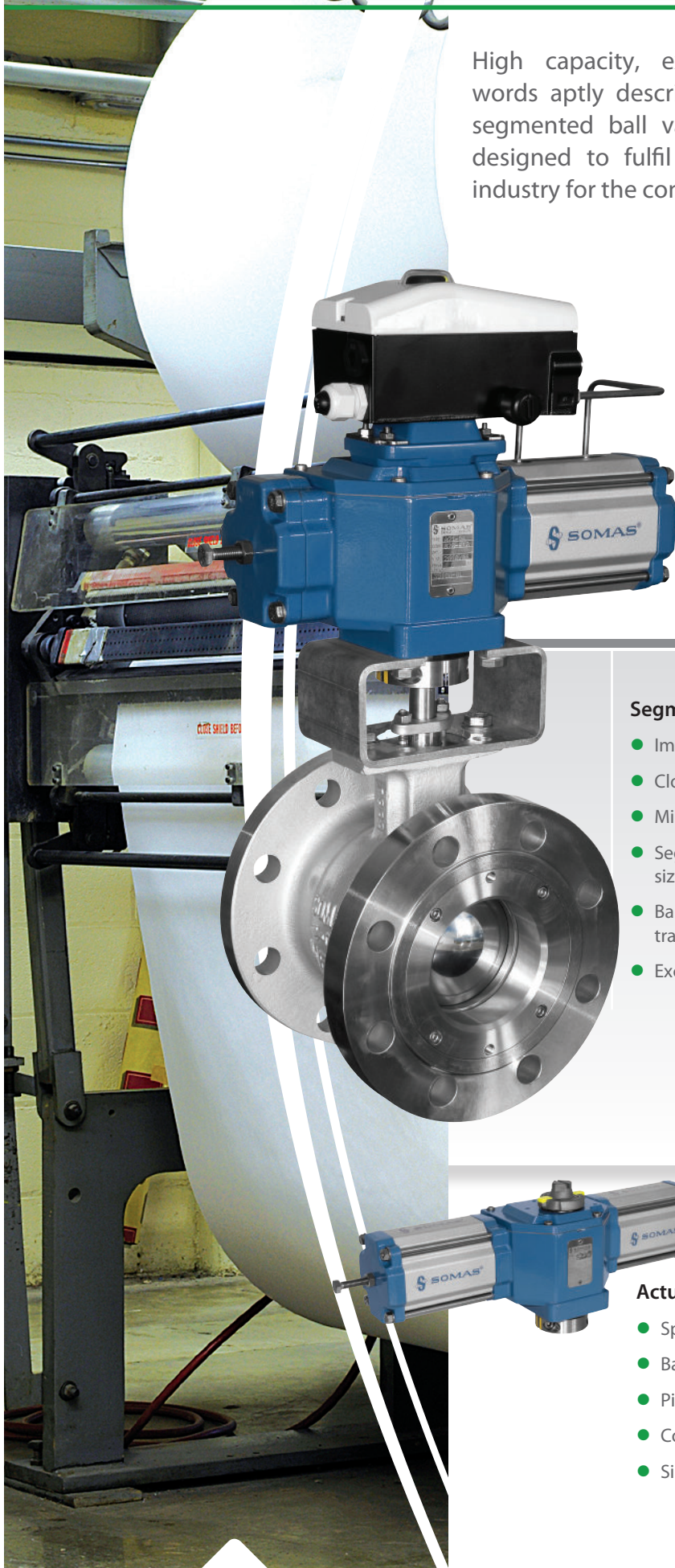

### Segment and V-notch ball valves for high capacity control

- Improved opening characteristics for control applications
- Close to linear opening characteristics
- Minimised clogging due to free flow design
- Segment design improved flow characteristics affords a smaller sized and more economical valve than typical alternatives
- Ball segment and shaft made in one piece to give a torque transmission free of backlash
- Excellent tightness irrespective of differential pressures

### Actuators and positioners

- Specially designed for the process industry
- Backlash free
- Pin-point accuracy
- Complete with diagnostics
- Single acting and spring return options



### Segment ball valves for low noise at high differential pressures

- Ball segment is machined with a low noise trim
- Despite the network of bars design the valve is still capable of passing fluids with medium fibre concentration
- Unique low noise segmented bars to reduce noise
- Rugged in design and construction for long life in harsh environments



### Float ball valves for sealing against low differential pressures

- Class VI sealing even at the lowest differential pressures due to spring loaded double seats
- Precisely engineered full bore ball in hard chrome or HiCo
- Seats options include reinforced PTFE and carbon filled PTFE
- Designed to meet applications such as contaminated media

## SEGMENT BALL DESIGN

### V Groove

- Eccentrically mounted V Groove segment ball reduces wear on seat and segment



### Low noise trim

- Equipped with a network of bars to split up the pressure drop across the valve

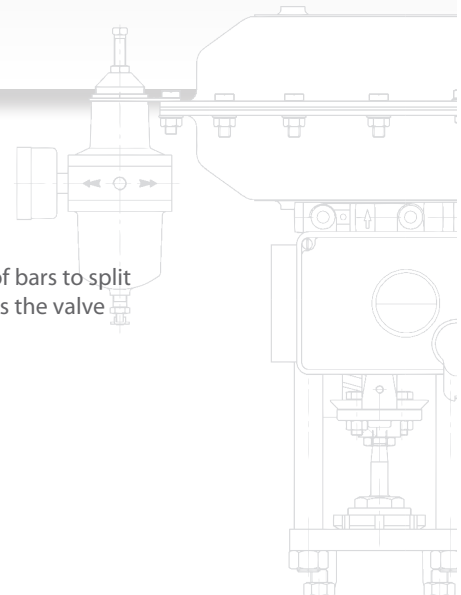



## Energy centre and steam system specialists

We can be of real benefit to you in the steam and condensate loop. Our steam system designers are called upon to design, specify and supply full equipment packages. We are relied upon to give unbiased support and advice to ensure you get the right product for the right application.

Our product range in this area is boiler control equipment such as level, TDS and blowdown systems, pressurised de-aerator plant, severe service control valves, turbine bypass valves and de-superheating stations, combustion efficiency and monitoring, heat recovery, flue gas recovery and water treatment.

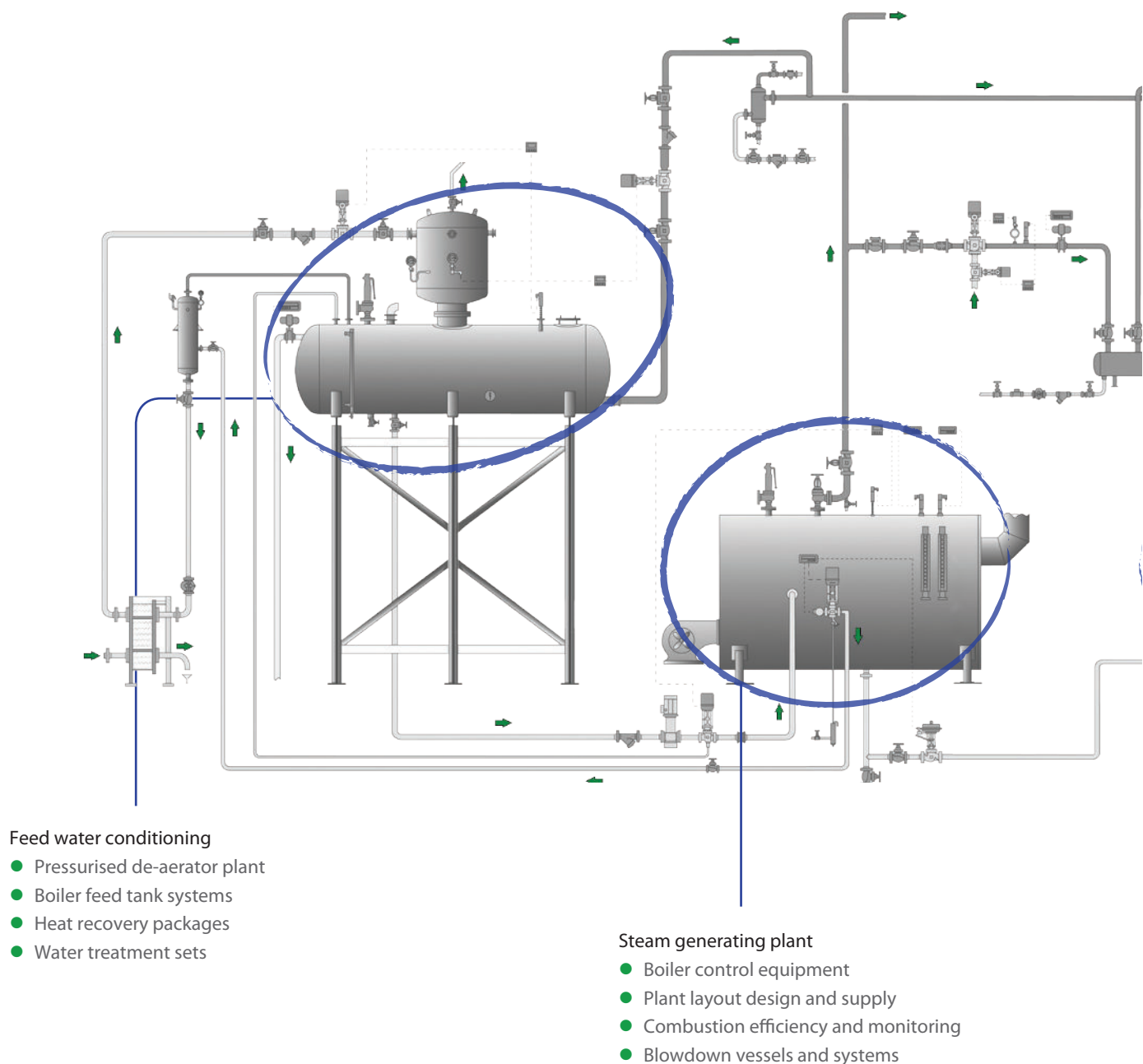

FOR ILLUSTRATION PURPOSES ONLY.  
Subject to change without prior notice

# In total control...

## Process control and distribution

- Control and process valve packages
- Severe service and turbine bypass
- De-superheating and letdown stations
- General pipeline ancillaries

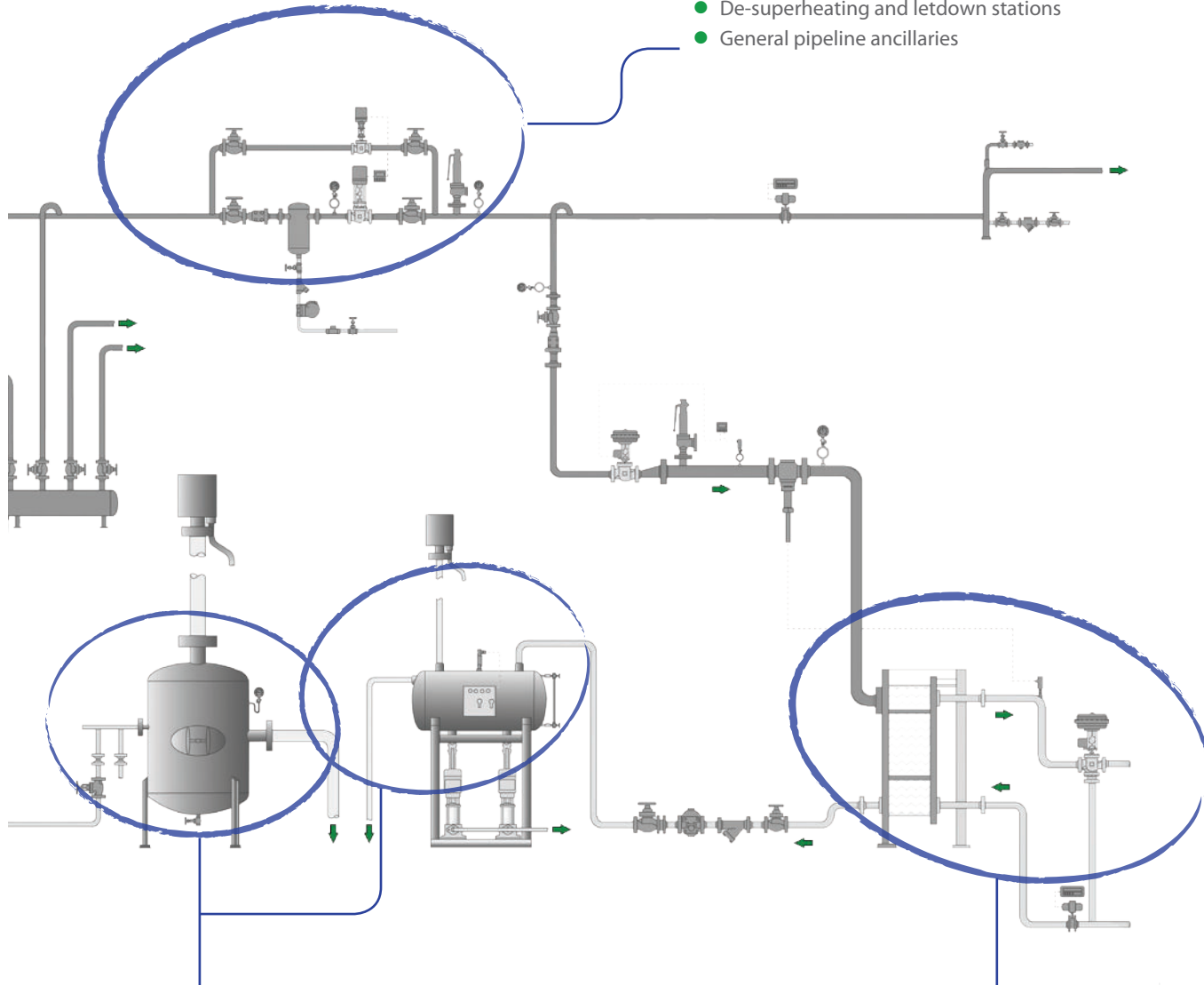

## Energy monitoring and recovery

- Flue gas heat recovery
- Steam, water and utilities metering
- Condensate recovery packages
- Pre-heater recovery systems

## Heat transfer packages

- Heating and cooling heat exchangers
- Off site prefabricated packages
- Plate, shell and tube, plate and shell
- Temperature process control loops

**valveforce**™  
the power in your process

## CONTROL VALVES : High Performance Butterfly

Our range of advanced triple offset high performance butterfly valves helps you adjust your flow and provides complete process isolation. The butterfly valves can be used on steam, gas, water and many other fluids to suit your site conditions. We only manufacture from high-grade stainless steel with a homogeneous metal seat as standard.



### High performance butterfly valves

- Class VI sealing characteristics due to triple offset design
- Minimal wearing due to triple offset design, homogeneous disc and seat materials
- Numerous materials of construction to meet process specific requirements
- Designed in consideration of demanding applications such as contaminated media





- The advanced triple eccentric design of the disc and the unique construction of the seat provides excellent shut-off and virtually eliminates the need for maintenance
- The high surface pressure between seat and disc makes the valve useful for pulp applications where the fibres are easily cut
- The MTV butterfly valve is the most cost-efficient choice for control and on/off applications
- All our valves are tested for leakage and meet the requirements of IEC 534-4 Class V for valves with SS 2377-seat or Class VI for valves with PTFE-seat

- The metal seat ensures that high-velocity flow will have no effect on the valves tight shut-off ability and allows for many years of operation
- Dimensions up to DN 1200, pressure classes PN 10-50 and the universal design allows for manufacture in many different materials and enables us to cover most applications in the process industry
- They can be installed by mounting between flanges, with or without lugs. The valves are also available fully flanged if required

( Unique minimal wear  
triple offset design )

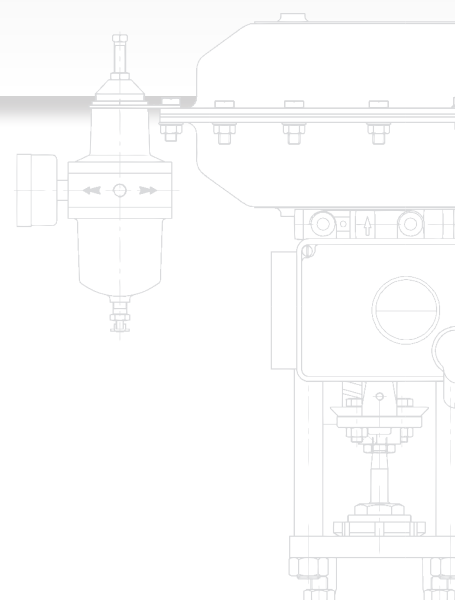

## SELF ACTING REGULATORS : Pressure

Our self-actuating pressure control valves are designed to maintain an adjustable set point for pressure control systems. Our range is self-actuating and therefore does not need an additional auxiliary energy supply such as electric or air.

Our range of self-actuating pressure control valves are easy to operate and set up, these are probably the most cost effective control valves available.

### Surplus and pressure maintaining valves

- For systems that require the upstream pressure to be controlled
- Available in direct acting and pilot operated models
- Complete range of sizes to cover the majority of applications
- Extensive body materials and end connections to suit most pressure and temperatures

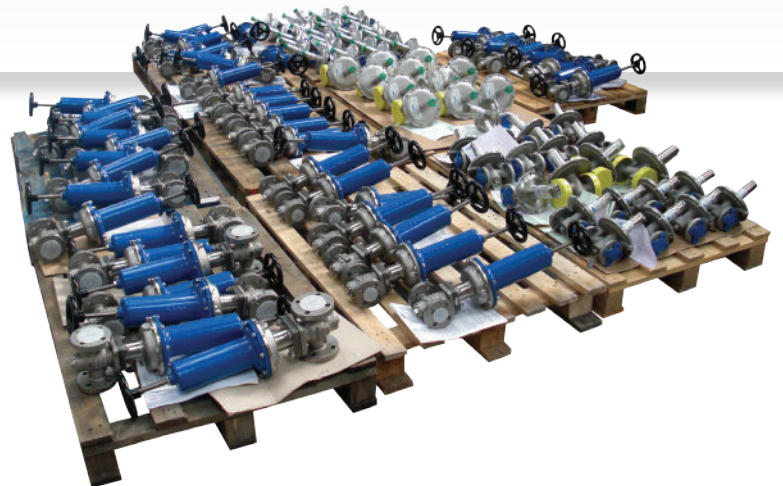

# SELF ACTING REGULATORS



## Pilot operated pressure reducing valves

- Accurate and steady pressure control even with fluctuating flow rates
- Different options suitable for steam, gas and air
- Easy to operate, setup and alter if required
- Compact and versatile in design, providing an economic solution



## Direct acting pressure reducing valves

- Very robust ensuring long life with minimal maintenance
- Operates in harsh applications with often large pressure drops and flow rates
- Available in larger sizes with balancing bellows for larger pressure drops
- Fully balanced for lighter capacities and range ability

( Valveforce in control  
under pressure )

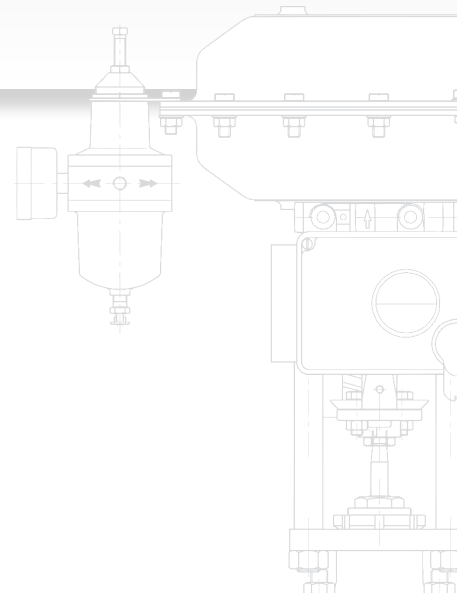



## SELF ACTING REGULATORS : Temperature

The thermostatic temperature controller, which consists of a thermostat and a valve, is used for controlling temperatures in central heating, district heating systems, industrial plants or marine systems. It can be used for the control of cold or hot water, steam or oil, in heating or cooling systems.

A self acting temperature control valve consists of a sensor and a capillary tube filled with liquid and an adjusting cylinder. The thermostat is self-acting and based on the principle of liquid expansion. It has a sturdy design and operates with a large closing force. The adjusting cylinder of the thermostat is set at the required temperature for the heated medium.

The temperature control is carried out by the thermostatically controlled valve, to reduce or increase the flow of the heating (or cooling) medium. If the temperature of the medium to be heated is above the required level the sensor liquid expands. This causes the piston of the thermostat to act upon the valve and reduce the flow of the heating medium.

If the temperature of the medium to be heated is below the required level the temperature of the sensor liquid falls. This reduces the volume of the liquid so that the piston allows the valve to open, under its internal spring, thus increasing the flow of the heating medium.

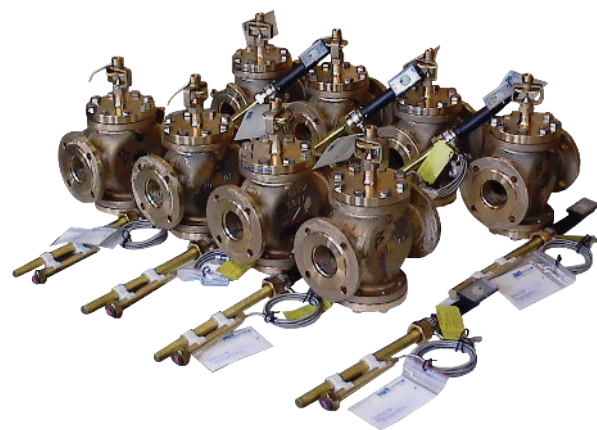

# SELF ACTING REGULATORS

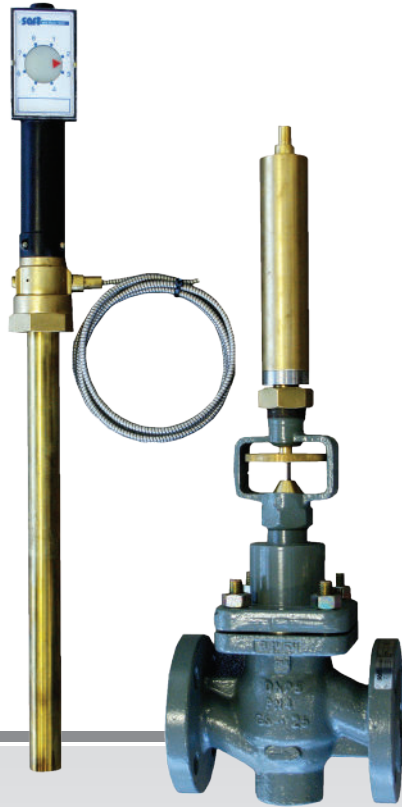

- Stable proportional control with narrow temperature band
- Friction free bellows for long life
- Easy to install, set up and commission
- Intrinsically safe in explosive areas



- Self acting without any pneumatic or electrical requirements
- Intrinsically safe in operation
- Suitable for heating and cooling applications
- A range of temperature feelers for demanding applications

( Feeling the way to better temperature control )

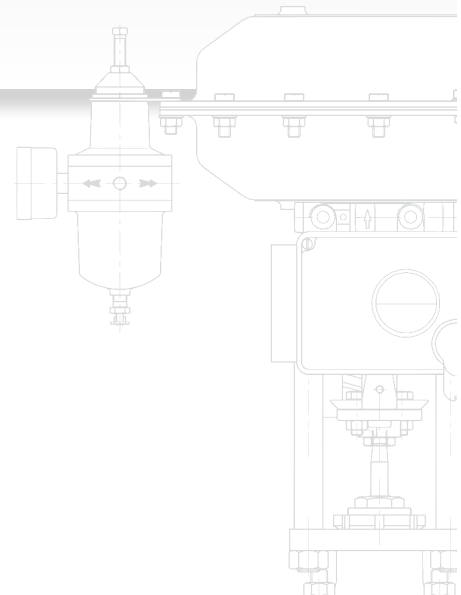



## PIPELINE PRODUCTS : Safety Valves

The main function of a safety valve is to protect property and life. A safety valve is an automatic valve specifically sized and designed to open and discharge fluid contents when the pressure reaches a predetermined "set pressure".

As a safety valve is often the last device to prevent catastrophic failure under pressure conditions, it is essential that our engineers evaluate the sizing criteria in detail to ensure the valve works at all times and is 100% reliable.



### High performance full lift safety valve

Flanged safety valves with especially high capacity for their size. With a large quantity of valve sizes, pressure ranges and product options they have proven themselves as a universal safety valve for many applications.

- All our safety valves feature quick pop action in the event of excessive pressure build up
- All valves have adjustable set pressures to allow fine tuning of the determined release pressure
- Our range includes closed bonnet, cap, open and gas tight to suit your plant
- Hygienic and critical service models available





**Modulating action safety valve**

Flanged safety valves with a standard or proportional opening characteristic. They minimise medium loss when opening and are used for thermal relief applications, liquid service and protection from pressure peaks.

- For two phase flow quick pop action in the event of excessive pressure build up
- All valves have adjustable set pressures to allow fine tuning of the determined release pressure
- Our range includes closed bonnet, cap, open and gas tight to suit your plant



**WRAS approved safety valves**

- We have a range of safety valves suitable for use on potable water
- Wetted bronze body internals manufactured from de-zincification resistant materials

( Valveforce in control and relieving the pressure )

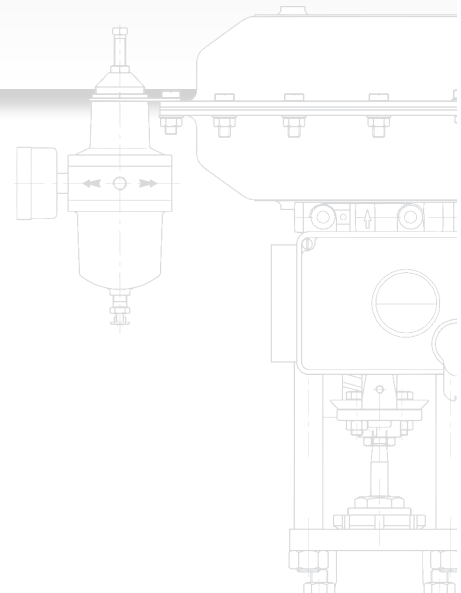

## PIPELINE PRODUCTS : Check Valves

Our Valveforce range is designed to fit between flanges, providing a compact installation when compared size for size with conventional swing and lift type check valves.

We offer a vast range of non return valves from stock. These valves are installed in pipeline systems to allow flow in one direction only. The flow is allowed to go in one direction which is then "checked" if the flow direction is reversed.



### Double disc check valves

- Split disc design overcomes all size and pressure drop limitations
- Eccentric disc reduces pressure drop characteristics further for maximum performance
- Suitable for very low pressure drops and frictional losses
- Available in conformance with API 594



### Spring and disc check valves

- The most cost effective solution for small to medium pipes
- Design advantages include: rapid opening and closing characteristics with spring allowing for a minimum opening pressure to be set
- Ideal on boiler feed lines where they can protect the boiler and feed water tank from flooding by use of a heavy duty spring
- High pressure model PN64-100 available



### Tilting disc check valve

- Rapid response with the oblique seat design which reduces closing travel
- Low pressure drop and low opening pressure
- Minimal flow interference through the valve
- Excellent tightness and superior surface finish



### Swing check valves

- Useful alternative to spring and disc valves with less limitations on size
- Simple and cost effective in construction for specific applications
- Designed for high particulate in the fluid
- Various options for O-ring seat

Shorter face to face design for easier maintenance, easier installation and lower costs

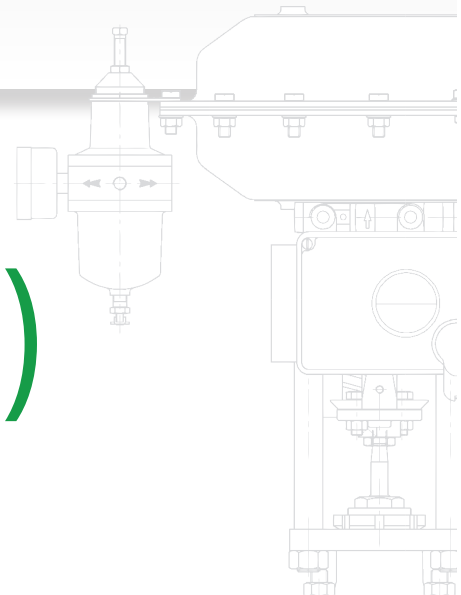



## PIPELINE PRODUCTS : Flow Isolating Valves

Our Valveforce range fully complies with the requirements of Pressure Equipment Directive 97/23/EC and carries the CE mark.

A cost effective and complete range of isolating stop valves are suitable for most applications such as steam, air, thermal oil and other neutral non aggressive media up to 350°C.



### Bellows sealed stop valve

- Double bellows sealed for environmentally friendly zero emissions
- Energy saving stem seal so losses are eliminated
- Safer to work around as no dangerous leaks
- Save energy, promote a cleaner environment



**Gland packed stop valves**

- Graphite packed for a cost effective solution
- Full range of sizes and body materials available
- Stainless steel internals for a robust service and reliable shut off
- Easy to maintain and a low cost of ownership



**Butterfly valve packages**

- Soft seated shutoff valves
- High performance double and triple offset
- PTFE lined for high corrosive media
- Wafer, lugged and double flanged pattern



**Knife gate valves**

- Uni direction for liquids with low solids
- Bi direction for liquids with higher solids
- Resilient seated for water and sewage
- Complete range of actuation and control

A complete cost effective range of products available from stock

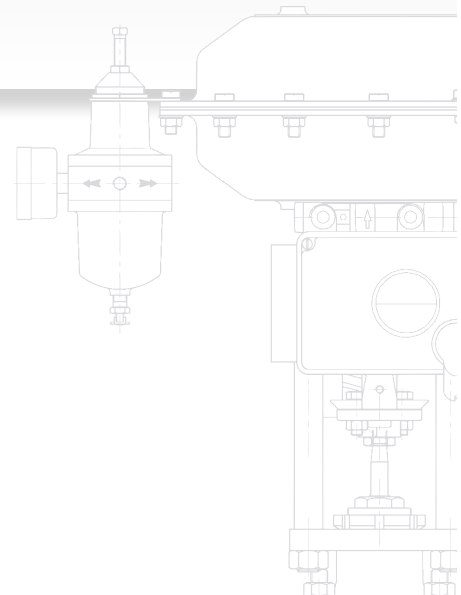

## PIPELINE PRODUCTS : Ball Valves and Strainers

Our comprehensive range of ball valves have an outstanding reputation for quality and reliability. From cost effective versions through to high specification top end products to suit the most demanding of applications.



### Quarter turn ball valves

- ON/OFF valves to suit most applications
- Reduced and full bore to ensure low pressure drops and high capacities
- Available as control valves with full actuation packages
- Trunnion mounted and floating ball





## Process automation

- Automated ball valves for process control
- Positioner, switch box and limit switches
- Double acting and spring return actuator
- Quarter turn electric actuator with fail safe option

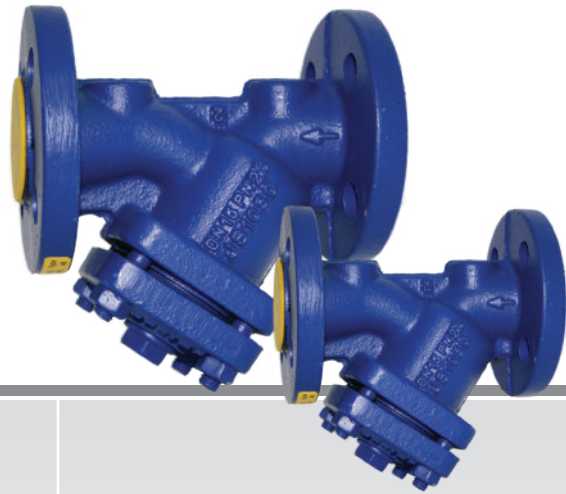

## Y type strainers

- Designed to remove solids and particulates from the media
- Various mesh sizes available including fine meshes for steam application
- Bolted end cap with a drain plug for ease of cleaning
- A full range of materials, size and end connections

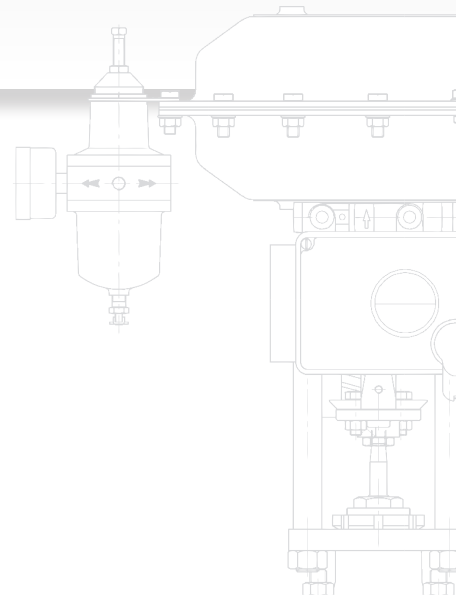

## STEAM SOLUTIONS : Traps, Separators and Pump Sets

Whether you need a full system specifying and designing or a complete system audit consult us at Valveforce for independent and impartial steam advice.

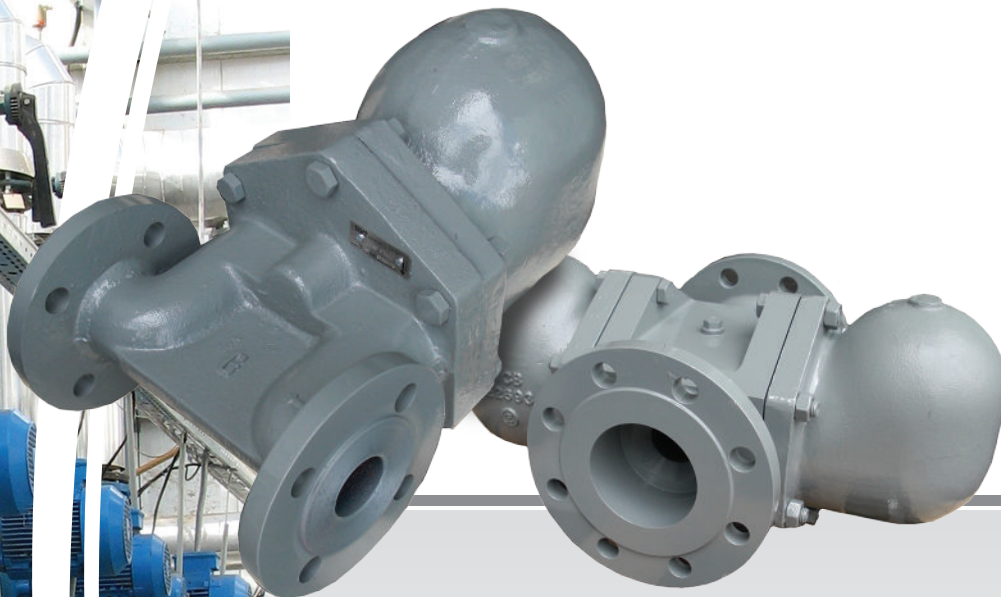

### Steam traps

Steam trapping is an essential and critical part of the steam and condensate loop. It is advisable to take our specialist advice to ensure that the correct steam trap is sized and specified correctly. Also important is the pipe work layout and geometry which may also cause site problems. If you need advice then please do not hesitate to speak to one of our engineers.

### Our range includes

- Mechanical traps such as ball float traps and bucket traps. Ideal for use on heat transfer packages where there are often varying loads.
- Thermodynamic traps are compact, lightweight, not affected by water hammer and are very well suited for steam mains drainage.
- Thermostatic traps are used on a vast amount of applications where you might want to use some of the sensible heat in the condensate and reduce live steam loss.

( Valveforce independent  
steam system experts )



**Heat transfer packages**

- Latest heat transfer packages
- Pre-fabricated heat exchangers
- Plate, shell and tube, plate and shell
- Automated for the complete package



**Skid pumps**

- Mechanical pumps specifically designed to remove condensate
- Self contained system using steam for motive power
- No electric motors or switches, ideal for hazardous areas
- Pump at high temperatures avoiding cavitation



**Separators**

- Centrifugal separators remove up to 98% of condensate. As steam passes through the separators' cyclonic cone centrifugal forces push condensate outwards
- Reduces erosion and corrosion
- Protects plant from high velocity wet steam
- Ensures maximum heat transfer efficiency



**Condensate recovery pump sets**

- Stainless steel atmospheric collection vessel with electric pump sets
- Duty and cascade pump control for efficient recovery of valuable condensate
- Prefabricated and robust in design for reliable long life
- Complete level control system duplex duty/standby



**Flash vessel**

- Designed and constructed in compliance to PED
- Integral part of a heat recovery system
- Low separation velocity to produce drier steam
- Free draining for boiler blow down application

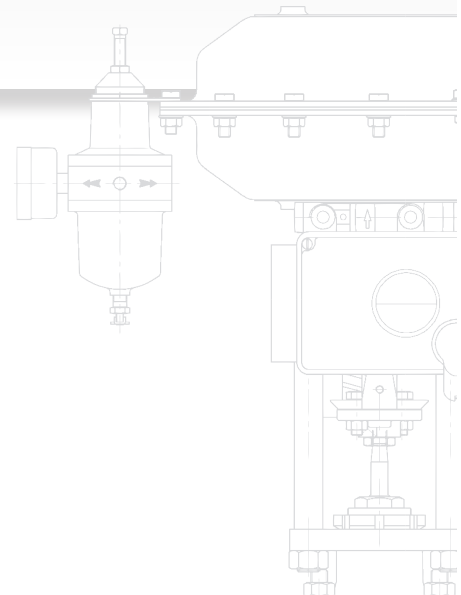



## HYGIENIC : Clean Service Control Valves

Our hygienic range of valves are designed to meet sterility requirements across the process sector. Fitted with BPE clamp fittings, conforming to FDA, ASME and ISO standards, the joint seals of these valves are free from the dead zones which are responsible for debris build up.

Polished surface finishes further reduce the possibilities of impurity build up and are chosen to a fineness suitable to the application. Included in this range are valves to meet the highest purity standards, as found in the pharmaceutical and semiconductor industries.



### Three port angle design

- Accurate control of high purity media
- Designed with quick release body and bonnet
- Three port design for fluid mixing
- Comprehensive material traceability and certification



### Two port angle design

- 316L stainless steel construction
- Self-draining crevice free design
- FDA approved seals
- EHEDG and 3A's approval
- Quick release body and bonnet



### Two port horizontal design

- High grade stainless steel for use on potable water
- Equal percentage or linear control characteristics
- Various valve seat and stem options
- Various end connections to suit the application

( Complete range of control  
valves for clean service )

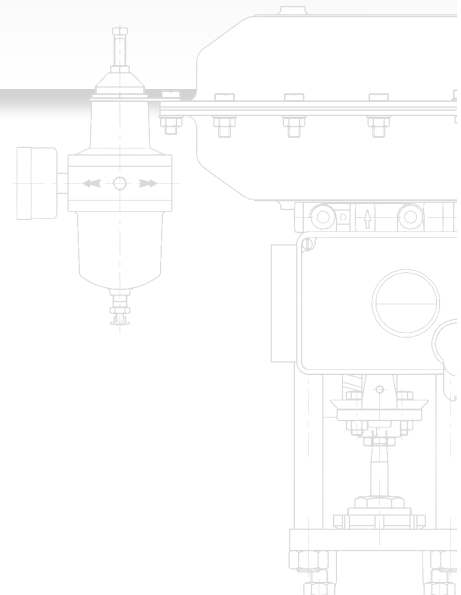

## The Valveforce Vision

To be the ultimate expert partner of choice  
for energy and flow control solutions

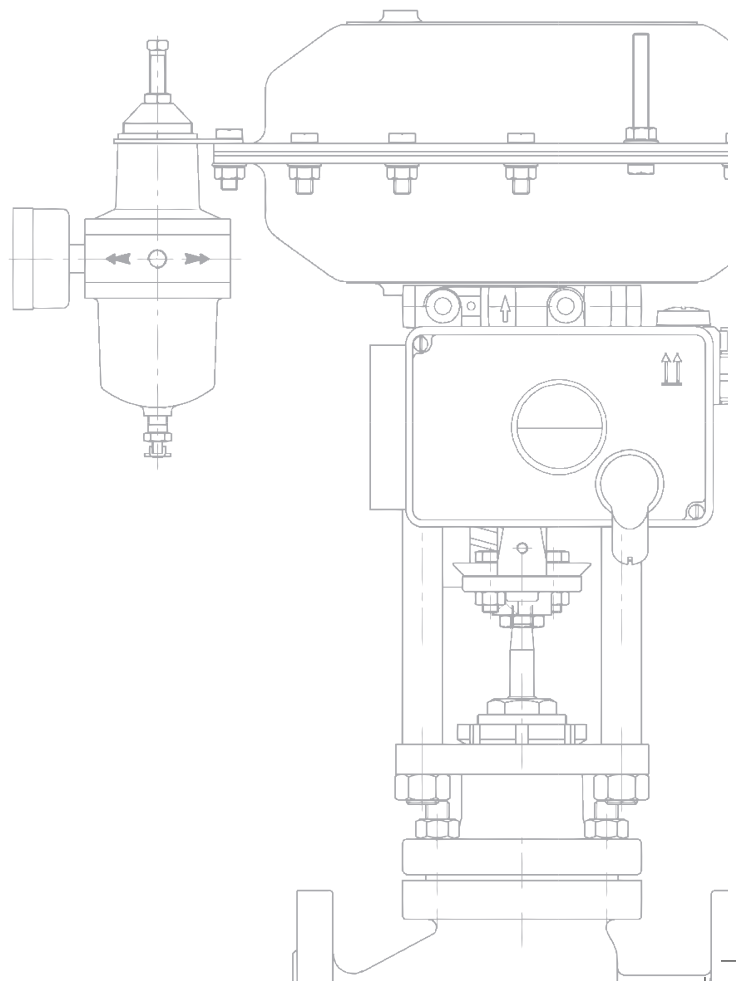

 +44 (0) 121 7111 908

 +44 (0) 121 7111 909

 [info@valveforce.co.uk](mailto:info@valveforce.co.uk)

 [www.valveforce.co.uk](http://www.valveforce.co.uk)