



Engineered
Services

*We are committed to providing industry
with the latest technology, consistent high
quality, outstanding reliability and the
highest levels of performance.*



Welcome to *Valveforce Engineered Systems*

Our business purpose is to engage with our customers, building long term trusted partnerships by providing independent expert advice and support services to ensure optimum plant performance and energy efficiency.

At the core of our company is an exceptional team. They are highly trained, experienced, proactive engineers, technicians and sales support staff who play a vital role in Valveforce's reputation for reliability and outstanding customer support.

We offer all the advantages of big company support and back up whilst remaining firmly focused on the virtues of close customer contact and genuine personal service.

Valveforce is part of The Force Group and can therefore offer integrated turnkey solutions across a diverse range of industries for all your system needs. At The Force Group we are a dedicated multi-disciplinary team with product specialists you can count upon as an extension to your organisation. We offer a fully comprehensive range of products and complementary services for Valves, Heat Exchangers, Controls & Instrumentation and Pumps. Our aim is to fully align ourselves to what our customers are asking us for: dedicated expertise and cost-effective solutions to support them on or off site.

Marc Bozdogan
Managing Director



Our Comprehensive Range of Services

Support and on-site solutions

In recent years our customers' requirements have changed. This is due to the significant loss of engineering expertise and manpower to carry out the detailed engineering work. At Valveforce we are relied upon more and more as a specialist extension to our customers team, providing valuable support services where required.

With the manpower and core competencies we have available our engineers will work with you to improve, monitor and maintain your plant and your processes. Our comprehensive range of service products are specifically tailored to meet our customers' requirements.

Specification and design

Designing the right solution

Our team will walk the plant with you to assess your requirements. We can then apply our extensive valve and associated technology expertise to offer you a structured independent recommendation for the improvement of your process efficiency, productivity and plant effectiveness.

We will look at ways to:

- Reduce energy consumption and recover valuable heat that can be lost from your process
- Ensure steam plant and steam traps are surveyed and working efficiently
- Give you the peace of mind that your equipment is being looked after by experienced independent engineers
- Work alongside you to ensure value for money and improved return on your plant investment

Rely on Valveforce to design, specify and supply your full equipment package. You will receive independent support and expert advice to guarantee the right product for your application.

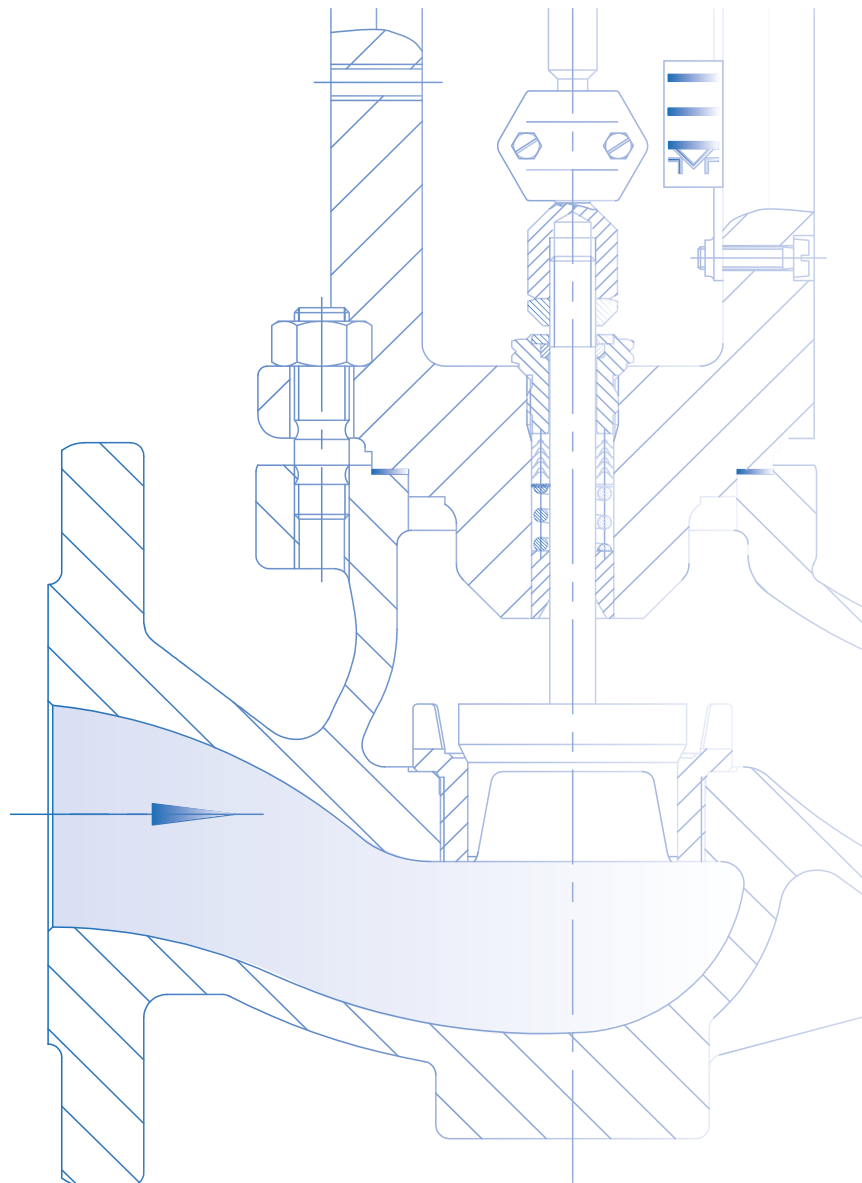



Maintenance and service

Increasing your uptime

Our technical maintenance service will ensure that your products are regularly tested and maintained. We will leave you with the peace of mind that your systems are working as efficiently and effectively as possible. We will also help to protect you from plant failure and ensure that you are compliant with all personnel safety and environmental policies.

You will benefit from:

- Control valve servicing and testing
- Isolation valve overhaul and repair
- On site test and calibration
- In-situ valve testing and reconditioning
- Annual safety valve servicing agreements
- Steam and energy surveys

Installation and commissioning

Turnkey projects delivered on time

As relied upon experienced engineers, we are able to carry out the complete turnkey installation through to commissioning and acceptance sign-off.

The installation will be carried out by experienced specialists to avoid any post-installation delays. Our installations are specifically project-managed to ensure tight project time scales are met and the contract is delivered on time and on budget.

These projects and products can then be supported by our aftersales team, who will organise support services such as maintenance contracts, performance reviews and reporting if required.

Your complete services includes:

- Project management
- Delivery scheduling, off-loading and positioning
- Mechanical and electrical installation
- Thermal insulation and cladding
- Calibration and commissioning
- System test and system integration
- Documentation and acceptance sign-off





Boiler House Service Agreement

How critical is your steam supply

Planned preventative maintenance to your steam generating plant is critical to ensure that the steam distribution system is operating economically, efficiently and safely. A Valveforce annual Boiler House Service Agreement provides you with the peace of mind you require for the continuous operation of your energy centre equipment.

Valveforce are offering:

- An energy centre maintenance procedure that supports the requirements of the latest boiler house guidance notes
- Working together with our team we can pull together a Planned Preventative Maintenance (PPM) programme to minimise costly downtime and release maintenance staff for other duties core to your business
- Removal, calibration and maintenance of boiler control equipment such as level probes, TDS and bottom blowdown systems
- The peace of mind that your equipment is being looked after by experienced independent engineers
- The ability to improve maintenance budgeting, cost planning and avoid those costly emergencies

Service Agreement Summary:

- Planning your maintenance will ensure that your system integrity is maintained and any maintenance issues are avoided
- Use our dedicated and experienced controls engineers as a valued extension to your own team
- Valveforce's Boiler House Service Agreement safeguards against emergencies by scheduling in routine inspections
- Our service agreement ensures that you have planned your budgets which can help eliminate costly surprises
- Spares and components are allocated and held in stock ready for site attendance and overhaul
- On-call service engineers and priority bookings with reduced rates for service visits
- Potential for yearly 24/7 emergency cover and personal technical support

Valveforce's Boiler House Service Agreement ensures planned regular maintenance and servicing of boiler house equipment. All work is carried out by specialist Valveforce Service Engineers. An initial audit of the boiler house system is undertaken with the customer prior to commencement of scope of work. The service typically includes the following:

	WORKS UNDERTAKEN	
	6 Month visit	Major visit
ON / OFF and Modulating Boiler Water Level Controls		
Extract the level probes, clean, inspect, check for fatigue and replace using new seal gaskets.	–	✓
Remove and strip down globe control valve to inspect trim and clean spindle, replace packing once per year. Reassemble body using a new cover gasket, inspect electric actuator motors and potentiometer for wear and travel. Visually inspect the controller for integrity. Check all terminations for tightness and electrical contact.	–	✓
Inspect bases to ensure good electrical contact is made.	✓	✓
Test controls with an empty and depressurised boiler then bring up to normal working level with attention to firing the burner and testing cut-out on low water alarm conditions.	✓	✓
Test that the controls are working at normal working pressure.	✓	✓
Carry out a functional test of remote boiler shutdown panel.	✓	✓
Suspended Solids TDS Control systems	–	✓
Extract the TDS probe, clean, inspect, check for fatigue and replace using new seal gaskets. Visually check blowdown valve for gland leakage, replace packing once per year. Strip down TDS valve and inspect high pressure drop internals for excessive wear at least once per year.	–	✓
Take a boiler water sample then compare to TDS controller set point. Recalibrate controller to ensure that only the required amount of boiler water is being discharged.	✓	–
Witness and functionally test the TDS system for correct operation.	✓	✓
Manual and Automatic Bottom Blowdown Control		
Visually inspect the controller for integrity. Check all terminations for tightness and electrical contact.		
Inspect bases to ensure good electrical contact is made.	✓	✓
View timed bottom blowdown settings and ensure optimum times for maximum boiler efficiency. Record settings.	✓	✓
Visually inspect the blowdown valve, actuator and solenoid valve.	✓	✓
Functionally test system to ensure correct operation.	✓	✓
Hotwell and Feedtank Level Controls		
Extract the level probes, clean, inspect, check for fatigue and replace using new seal gaskets.	–	✓
Remove and strip down globe control valve to inspect trim and clean spindle, replace packing once per year. Reassemble body using a new cover gasket, inspect electric actuator motors and potentiometer for wear and travel.	–	✓
Visually inspect the controller for integrity. Check all terminations for tightness and electrical contact. Inspect bases to ensure good electrical contact is made.	–	✓
Blowdown Vessel Cooling System		
Remove and strip down self-acting control valve to inspect internal trim, clean spindle and lap in the seat.	✓	✓
Reassemble valve using new body gaskets and inspect self-acting temperature controller.	✓	✓
A service report is provided per visit, noting findings, corrective actions and any recommendations.	✓	✓

Spares used during service visit include:

Feedwater control valve stem seal and bonnet gasket, gasket and packing set for TDS system.

PLEASE NOTE If the boiler is able to be brought back up to pressure during the service visit, then the controls will be tested and proven.

Burner Service Agreement

Valveforce's unparalleled Gas and Dual Fuel Combustion Burner Service Programme

By choosing a Valveforce Service Agreement to service your Boiler Burners, you will receive a dedicated service scope tailored to your burner, a specialist programme undertaken by our experienced Service Engineers to ensure your boilers are running at optimum performance and so preventing costly breakdowns.

Valveforce's Burner Service agreement is a planned approach to preventative maintenance which provides peace of mind that all your boilers are running at optimum performance and so preventing costly breakdowns.

- Assuring that your Burners are operating at optimum performance and helping to maximise burner efficiency
- A maintenance programme to ensure your burner is being serviced to manufacturer's recommendations, reducing the risk of costly breakdowns
- Predictable maintenance budget planning and forecasting
- Planning your maintenance will ensure that your boiler integrity is maintained and breakdowns are avoided
- A rapid response from experienced Service Engineers at minimum cost
- The use of genuine OEM spares
- Priority response for peace of mind that your burners are covered in the eventuality of a breakdown
- Reduced call-out rates for service agreement customers
- Components held in stock ready for site visits
- A detailed review following each scheduled visit

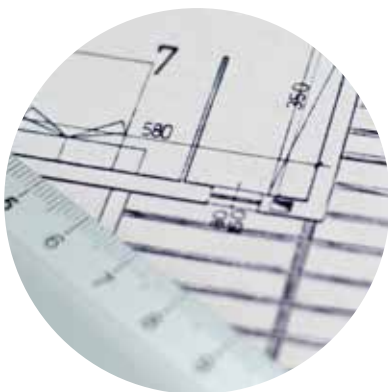

SPECIFICATION & DESIGN *Designing the right solution*

Consultative technical approach
Steam and condensate engineers
Specialists in flow control systems



SUPPLY & INSTALLATION *Delivering turnkey projects*

Complete turnkey offering
Impartial technical advice
Right product at the right price



SERVICE & MAINTENANCE *Increasing your up time*

Overhaul and repair facilities
Energy recovery and plant audits
Annual service agreements

Working together to improve your Industrial Boiler and Burner Services.

Maintaining all types of Industrial Steam and Hot Water Boilers and Burners.

Valveforce's Burner Service Agreement ensures your steam and hot water burners are regularly maintained by our specialist Valveforce Service Engineers. Annual agreements typically consist of a 6 monthly running check and an annual Major Service:

	WORKS UNDERTAKEN	
	6 Month visit	Major visit
Open up the burner and remove the burner head	-	✓
Check and clean the diffuser, checking for damage	-	✓
Remove, inspect and clean the ignition assembly, photocell and probe	-	✓
Check ignition electrode for cracks and wear	-	✓
Check HT cap and leads for signs of arcing	-	✓
Check pressure switches for damage and signs of water ingress	✓	✓
Remove and check gas valve actuators for signs of oil leakages	-	✓
Check control panel and terminal boxes for the integrity of the wiring and contactors	✓	✓
Inspect and clean oil filters on pipework and oil pump	-	✓
Fire the burner, check combustion through the full range and adjust as required for optimum efficiency	✓	✓
Check all burner safety devices are functioning correctly and set to the correct parameter	✓	✓
Carry out full combustion analysis and print out results	✓	✓

Exclusions and limitations:

- Combustion adjustments are only applicable when burner control panel pass codes are available
- The boiler will be out of service for up to 4 hours during the major service, production should be made aware of the interruptions



Annual Boiler Insurance Inspection

Are you meeting your statutory obligations?

Valveforce engineers are able to carry out the boiler preparation for your annual insurance inspection and 5 yearly Non-Destructive Testing in line with your statutory insurance obligations.

We will liaise and work alongside your insurance inspector to ensure the works are completed to the satisfaction of the insurance company and ensure you are meeting your statutory obligations.

Our engineers will prepare the boiler for the insurance inspection, overhaul and certify all the critical valves and on completion of the inspection the boiler is rebuilt, filled and tested. We then carry out the working test to satisfy the inspector.

Other services include:

- Boiler NDT Preparation
- BG01 Boiler House Upgrades
- Boiler Burner Servicing
- Boiler House Audits



Valveforce's Annual Boiler Insurance Inspection agreements ensure your steam and hot water boilers are prepared for their annual inspection and rebuilt by our specialist Valveforce Service Engineers. Annual agreements typically consist of a yearly preparation of boilers for insurance inspection.

	WORKS UNDERTAKEN	
	Steam	Hot Water
Drain down boiler and de-pressurise.*	✓	✓
Remove pressure gauges	✓	✓
Remove safety valve, strip, clean, rebuild, calibrate to set pressure and fit or install new safety valve	✓	✓
Remove crown valve, strip, clean, rebuild and fit	✓	-
Remove bottom blowdown valve, strip, clean, rebuild and fit	✓	✓
Remove water level controls, clean and refit	✓	✓
Remove water gauge glasses, strip, clean, rebuild with new packing and glasses and fit	✓	-
Open up front and rear smoke box covers to access flue ways and clean as required	✓	✓
Remove mud and man lids and inspect the waterside of the boiler	✓	✓
Remove water inlet and non-return valves, strip, clean, repack, rebuild and fit	✓	-
Remove auto TDS control valve and probe, strip, clean, repack control valve, rebuild and fit	✓	-
Reseal and close up smoke box covers	✓	✓
Reseal and refit mud and man lids	✓	✓
Refill Boiler*	✓	✓
Warm up boiler, bring up to working pressure and test safety devices	✓	✓
Over pressurise boiler to test and witness safety valve lifting (Insurance inspector to witness)	✓	-
Full report detailing works undertaken and any further recommendations	✓	✓

* To be confirmed with site requirements

Spares used during the rebuild of the boiler include:

- Water gauge packing and glasses, smoke box and man lid seals, valve packings and seals

Exclusions:

- Removal of major scale deposits due to poor water treatment regime
- Removal of major deposits from the flue ways due to build-up of excessive soot caused by poor combustion
- Removal and replacement of brickwork
- Calibration of pressure gauges
- Any subsequent repairs resulting from failure of NDT

Heat Exchanger Service Agreement

An independent service programme specifically for steam and hot water heat exchanger packages

For Valveforce Heat Exchanger Package customers, our Service Agreement offers a high level of care which delivers many benefits:

- Assurance that your Heat Exchanger Package is operating at optimum performance and to original design conditions, helping to maximise your process efficiency
- A maintenance programme to ensure your Heat Exchanger Package is being regularly serviced to manufacturer's recommendations, reducing the risk of breakdowns
- A rapid response from experienced Service Engineers, at minimum cost
- The use of genuine Valveforce or OEM spares, ensuring rapid delivery of the highest quality materials
- Predictable maintenance budget planning and forecasting
- Minimal spares stockholding
- Risk of product failure is reduced by keeping your process temperatures and pressures at peak performance
- Our service agreement ensures that you have planned your budgets which can help eliminate costly surprises
- Components held in stock ready for site attendance and overhaul.
- On-call Service Engineers and priority bookings
- Reduced rates for service visits
- Potential for yearly 24/7 emergency cover. Personalised technical support Monday to Friday
- The option to have spares delivered to your doorstep and fitted that day
- A detailed review following each scheduled visit

Service Agreement

By choosing to protect your Heat Exchanger Package equipment with a service agreement, you will receive a specialist maintenance programme that not only ensures your system is running at its best, but helps to minimise costly downtime. There is never a convenient moment for your system to break down, so a proactive preventative maintenance approach can help ensure smooth and efficient plant operation.

All service visits are handled by Valveforce's nationwide network of Service Engineers. Their knowledge of the Heat Exchanger Package system is second to none and you can be confident your equipment is in the best hands.

As part of your Service Agreement, you will receive a written overview of the work undertaken during each visit, together with details of replacement parts and the overall condition of your Heat Exchanger Package unit.

Service Agreement Summary:

- Planning your maintenance will ensure that your system integrity is maintained and any maintenance issues are avoided
- Using our dedicated and experienced controls engineers as a valued extension to your own team



Valveforce Service Agreement delivers regular maintenance and servicing of your Heat Exchanger Package units carried out by specialist Valveforce Service Engineers:

	WORKS UNDERTAKEN	
	6 Month visit	Major visit
Annual agreements typically consist of two visits per heat exchanger package unit per year		
Strip control valve, clean and visually inspect valve seat and plug		✓
Inspection of control panel, controller, valve and actuator	✓	✓
Inspection of all wiring diagrams and terminations to ensure integrity	✓	✓
Integrity check all electrical connections for tightness	✓	✓
Check set up of high limit temperature controller	✓	✓
Replace valve stem seals (if required)	-	✓
Check valve/actuator/positioner, zero and stroke and adjust if necessary	✓	✓
Check circulation pump is working correctly	✓	✓
Ensure correct operation of piston actuated valve	✓	✓
Functionally test to ensure correct operation and satisfactory temperature control	✓	✓
High Temperature Controls		
Inspection of control panel, controller, valve and actuator	✓	✓
Inspection of all wiring diagrams and terminations to ensure integrity	✓	✓
Integrity check all electrical connections for tightness	✓	✓
Check set up of high limit temperature controller	✓	✓
Strip control valve, clean and visually inspect valve seat and plug		✓
Optional test of high limit system to ensure correct operation	✓	✓
Plate Heat Exchanger Pack		
Visually inspect PHE pack for leakage (we can fully re-plate if required)	✓	✓
Condensate, Trapping or Pump Set		
Inspect pump/trap unit and test (6 monthly). Strip down and replace with new spares if required (once per year)	✓	✓
Functionally test line steam traps with leak detector	✓	✓
Components		
Check all strainer screens and clean if required	✓	✓
Temperature Control Check		
Ensure that secondary temperature is in accordance with site requirements	✓	✓
Additional Work		
Test operation of the skid system to ensure overall satisfactory control	✓	✓
Inspect all components of the skid system to ensure correct operation	✓	✓



Flow Metering Service Agreement

You can not conserve what you are not monitoring

Valveforce offer an extensive range of flow measurement solutions for liquids, compressed air, gas and steam. The installation of meters has become even more important in more recent years, as focus has been drawn to eliminating waste, accurate costings of utilities and detailed production costs. These flow meter systems are all too often installed, calibrated and then forgotten. Overtime flow meters can become unreliable and inaccurate which could lead to the following issues:

- Product failure due to inaccurate measurement
- Poor batch costing for analysis
- Over or under charging for utilities and services
- Inaccurate gauge of departmental consumption

Ensure accuracy with a Valveforce Service Agreement

Our flow metering agreement will ensure that you keep getting the most reliable and accurate from your systems, your flow meter will be maintained, checked and the loop will be recalibrated to ensure the most reliable data.

Our flow metering service agreement will be tailored to your requirements, but in general will consist of the following:

- Overall general assessment of current site conditions and ensure the correct equipment is installed
- Assessment of issues such as correct pipe diameters and K factors settings, turndown ratios, rangeability and low flow cut-off
- Frequent calibration of critical components such as DP cells, pressure and temperature sensors to demonstrate flow meter accuracy
- Overall a planned approach to your preventative maintenance policy to minimise issues associated with costly downtime
- Scheduled and planned-in main meter recalibration

Flow Meter Calibration

Overall we would suggest that a flow meter pipeline unit is recalibrated every 3 years if accuracy is key to its purpose.

Valveforce have the ability to test and calibrate both volumetric and mass flow meters with flows of a few litres per hour through to 60 litres per second using pipe diameters of up to 200mm.

The high tech calibration rig is designed to ensure an absolute concentric flow path to ensure highly accurate flow calibration, the stainless steel pipework is filtered and disinfected to ensure the systems are clean, free of debris and protected against contamination.

PLEASE NOTE Detailed calibration certification is supplied with every flow meter.

Service Agreement Summary:

- Planning your maintenance will ensure that your system integrity is maintained and any maintenance issues are avoided
- Using our dedicated and experienced controls engineers as a valued extension to your own team
- The risk of product failure is reduced by keeping your process temperatures and pressures at peak performance
- Our service agreement ensures that you have planned your budgets which can help eliminate costly surprises
- Components held in stock ready for site attendance and overhaul
- On-call Service Engineers and priority bookings
- Reduced rates for service visits
- Potential for yearly 24/7 emergency cover. Personalised technical support Monday to Friday
- The option to have spares delivered to your doorstep and fitted that day
- A detailed review following each scheduled visit

Valveforce Service Agreements deliver regular maintenance and servicing of metering equipment, carried out by specialist Valveforce Service Engineers. An on-site assessment of metering system performance is carried out with the customer prior to the commencement of scope of work, which typically includes the following:

	WORKS UNDERTAKEN
Visually inspect and assess that the installation is correct	✓
Visually inspect pipeline sensors and pressure transducer units (if possible)	✓
Inspect manifolds and impulse lines and blowdown if possible	✓
Check DP cells and transmitters	✓
Check all analogue inputs and outputs	✓
Using a signal generator confirm pressure and temperature inputs	✓
Note and record all results of checks and calibrations	✓
Visually check wiring and terminal connections on all electronic equipment and flow computers	✓
Ensure calibration settings are as per original factory settings	✓
Planned recalibration of pipeline unit (return to Valveforce)	OPTIONAL
Detailed service report generated detailing findings, next steps and recommendations	✓



Control Loop Service Agreement

Valveforce's unparalleled controls maintenance programme

The critical nature of control systems

Control valve loops are required to achieve accurate and repeatable control pressures and temperatures.

These systems are often not maintained or calibrated, which can result in poor temperature and pressure control leading to product failure and waste. Control valves are often in gruelling hardworking applications carrying out many cycles of operations, resulting in excessive wear and tear of critical components. All of which can be costly in terms of reduced efficiency, plant stoppages and unnecessary steam consumption.

A Valveforce Control Loop Service Agreement will give you the knowledge that you are maintaining your system's integrity and keeping your plant running safely and at peak performance.



Agreement Service Summary

Valveforce's Control Loop Service Agreement is a planned approach to preventative maintenance, which gives you peace of mind that all your control valves and applications are operating continuously and efficiently.

- Planning your maintenance will ensure that your system's integrity is maintained and any maintenance issues are avoided
- Using our dedicated and experienced controls engineers as a valued extension to your own team
- Valveforce's Control Loop Service Agreement ensures against emergencies by scheduling routine inspections
- The risk of product failure is reduced by keeping your process temperatures and pressures at peak performance
- Our service agreement ensures that you have planned your budgets which can help eliminate costly surprises
- Components held in stock ready for site attendance and overhaul.
- On-call Service Engineers and priority bookings
- Reduced rates for service visits
- Potential for yearly 24/7 emergency cover and personalised technical support
- A detailed review following each scheduled visit

Our Control Loop Service Agreement ensures that frequent maintenance and overhaul is planned in to maintain your Control Loop. The work is undertaken by independent specialist Service Engineers. We understand our customers' requirements prior to entering into a contract by discussing and assessing the current performance of the control loop to ensure their requirements are met.

	WORKS UNDERTAKEN	
	6 Month visit	Major visit
Manual and visual inspection of controller, valve and actuator	✓	✓
Physical and visual inspection of all wiring and terminations	✓	✓
Check all electrical connections for integrity	✓	✓
Check compressed air connections	✓	✓
Check the existing P.I.D settings in the controller to ensure accurate performance	✓	✓
Strip down the control valve, clean and visually inspect valve internals	-	✓
Replace valve gland packing (once per year as standard) and body cover gasket	-	✓
Check and clean all strainer screens, refit using new cap gaskets	-	✓
Set up control loop (valve/actuator/positioner), commission and stroke test	✓	✓
Functionally test to ensure correct operation and satisfactory temperature/pressure control	✓	✓
Detailed service report provided per visit, detailing findings, actions and recommendations/requirements	✓	✓

PLEASE NOTE That if the inspection suggests that full lapping and machining is required then this can be carried out but an additional proposal may be required.

Reduced Pressure Zone Valve Testing

Save time and money, whilst remaining compliant

Backflow protection devices are more commonly known as Reduced Pressure Zone valves or RPZ valves. They are used to protect water supplies from contamination due to backflow and back siphonage.

It is a legal requirement to have Reduced Pressure Zone valves tested on an annual basis or in some cases every six months, in order to provide the mandatory backflow protection and meet local water authority requirements. Testing must be carried out in accordance with the Water Suppliers' Approved Installation Method AIM-08-01.

Valveforce's Reduced Pressure Zone Valve Testing meets the Water Suppliers' Approved Installation Method AIM-08-01 and includes:

- RPZ valve testing
- RPZ valve commissioning & testing of new valves
- RPZ valve maintenance & repairs
- RPZ valve installation nationwide

Having your RPZ valve serviced by a Valveforce fully accredited RPZ engineer will save you time and money, and give peace of mind knowing that your RPZ valve has been correctly installed, commissioned and tested as per water regulations AIM-08-01.



Safety Valve Testing

Increasing your plant's uptime, output and bottom line

When testing critical components such as safety valves it is important to maintain plant productivity and safety, unfortunately with general test procedures the safety valve is required to be removed and maintained offline in a repair workshop. This outage and removal can often be very time consuming and costly in terms of man hours and manual handling equipment is often required.

Valveforce are able to eliminate this issue by offering a safety valve testing service which can prove and test the valves in-situ.

The Safety Valve Testing from Valveforce will cover:

- Live testing can be carried out without any downtime
- Accurate evaluation of set pressure, forces and lift
- Resetting of the set pressure can be carried out in service
- The equipment used is approved by Lloyds register
- Full documentation and test certification is provided

Our safety valve testing service means Valveforce are able to test safety valves, whilst in place and under live operating conditions.





Steam Trap Survey

Save energy and reduce your carbon emissions

To run a steam system at its optimum energy efficiency it is essential that all steam traps are operating correctly. Correct operation will ensure all condensate lines are cleared of condensate and steam losses through failed open traps are eliminated. By implementing a regular Steam Trap Survey carried out by Valveforce's experienced engineers, this will ensure steam traps are operating at their optimum and ensure steam and condensate systems efficiency.

A Valveforce Steam Trap Survey carried out on a regular basis is the efficient way to maximise energy efficiency, eliminate costly losses and minimise production downtime.

Detailed scope for each survey

A Valveforce Steam Trap Survey involves a detailed inspection of your condensate return system and delivers the following:

- Identification and inventory of the complete steam trap population
- Independent checking of each steam trap to ensure that it is correct for the application
- Visual inspection of each steam trap to check that it is installed correctly
- The latest ultrasonic testing of all steam traps in operation
- Highlight other issues that may be observed in your steam and condensate system
- Generation of an independent report as a result of the survey

We can save you money, reduce your carbon footprint and also ensure that your traps are working at maximum efficiency!

Your return on investment and energy savings

Valveforce's independent report will contain:

- A complete detailed listing of all your steam traps
- Precise operating conditions for each trap (at time of survey)
- A detailed report on the condition of the steam traps and associated ancillaries
- Accurate steam losses will be highlighted and calculated using your exact operating costs
- Calculated return on investment will be given for any remedial work that may be required
- Should other steam leaks such as gland leaks be identified then these will be also included
- An inclusion for other system recommendations maybe required



In addition we are able to offer:

- A competitive steam trap installation to carry out the remedial work
- Discounted prices for all steam traps and ancillary products identified during the survey

Steam Traps

Steam trapping is an essential and critical part of the steam and condensate loop. It is advisable to take our specialist advice to ensure that the steam trap is sized and specified correctly. Also important is the pipework layout and geometry which may also cause site problems.

Our range includes:

- Mechanical traps such as ball float traps and bucket traps are ideal for use on heat transfer packages where there are often varying loads
- Thermodynamic traps are compact, lightweight, not affected by water hammer and are very well suited for steam mains drainage
- Thermostatic traps are used on a vast amount of applications where you might want to use some of the sensible heat in the condensate and reduce live steam loss



Independent Steam System Audit

Optimising energy efficiency from your process plant

In these harsh economic times those operating steam systems face tough challenges from increasingly stringent health and safety legislation, increasing fuel costs and a decline in specialist skills. Valveforce has the experience and expertise to address these issues through its Independent Steam Systems Audit.

A Valveforce Independent Steam System Audit is impartial and specific to you. We understand your requirements and processes and offer a scope of works suitable to your financial requirements.

The extent of our audit can range from a brief energy audit within the boiler house through to a complete appraisal of your whole steam and condensate loop all fully drawn up, inventoried and documented.

Each audit is designed for you following a consultation with Valveforce's experienced engineers. Following the on-site work, a detailed and comprehensive report is produced and presented back to you.

Valveforce's Independent Steam Systems Audit comprises of:

- Typical areas for energy saving within the boiler house such as deaerator plant, heat recovery, economisers, pump VSD and flash recovery
- Identification of areas for potential savings in the steam and condensate loop to eliminate costly flash losses, recover more condensate, and improve lagging and insulation
- Discussion areas of where technology and new equipment can improve batch times and keep your plant running even more efficiently
- A full photographic library of your process plant with the ability to have access to datasheets and O&M instructions when you hover a mouse over them
- Full site drawings with existing and newly suggested improvements, along with a detailed valve component schedule and a recommended layout
- Identification of any health and safety issues or risk to your site operatives or the public

Valve Repair Services

Increase process efficiency and reduce capital costs with Valveforce's valve repair package

Leaking, sticking and problematic valves will lead to many site issues such as costly and often dangerous emissions, inefficient poor control and low seat isolation integrity which can be dangerous for site operators. Valveforce try to remain competitive for new valves, however replacing valves can often be expensive, labour intensive and often not practical from an operational point of view.

It is important that you work with experts to ensure your valves are performing at their optimum; ensuring your plant is being maintained, operating safely and costly downtime and emissions are eradicated.

Valveforce meet your needs by offering:

- In-situ online safety valve testing
- Routine valve repair at shutdown periods
- On-site valve repair and testing
- Workshop valve repair and testing
- Removal and reinstallation service

To discuss your specific requirement then please contact our office and talk to our engineering department.



Insulation Audit and Jackets

Saving heat and energy losses

Insulation jackets save energy, reduce carbon emissions and improve safety. Whether the system is steam, hot water or thermal oil, to operate the system at peak efficiency it is essential that all components are insulated. It is common for pipelines to be lagged, however control valves, strainers, steam traps and other ancillaries are often left bare resulting in energy losses through heat emissions.

By implementing a Valveforce Insulation Audit, operators will benefit from energy savings, reduced carbon emissions and improved health and safety.

Valveforce Insulation Jackets are the efficient way to maximise energy efficiency, reduce operating costs and reduce CO₂ emissions. Importantly plant safety will be enhanced by creating a cooler working environment and protecting personnel from hot surfaces.

Detailed scope for each Audit:

A Valveforce Insulation Audit involves a detailed inspection of your system and delivers the following:

- Identification of all uninsulated pipework and ancillaries
- Each requirement is measured for a bespoke insulation jacket
- A detailed survey report

Comprehensive Survey Reports:

- A complete inventory of uninsulated components
- The total cost of energy losses based on your specific operating costs
- Energy summary including heat losses and CO₂ savings
- The return on investment for complete rectification work
- Written recommendations for system improvements

Additionally:

- Full installation service to deliver the recommendations of the audit
- Preferential rates for all ancillary products identified during the survey
- Presentation of our survey and recommendations

Valveforce insulation jackets are the efficient way to maximise energy efficiency, reduce operating costs and reduce CO₂ emissions.

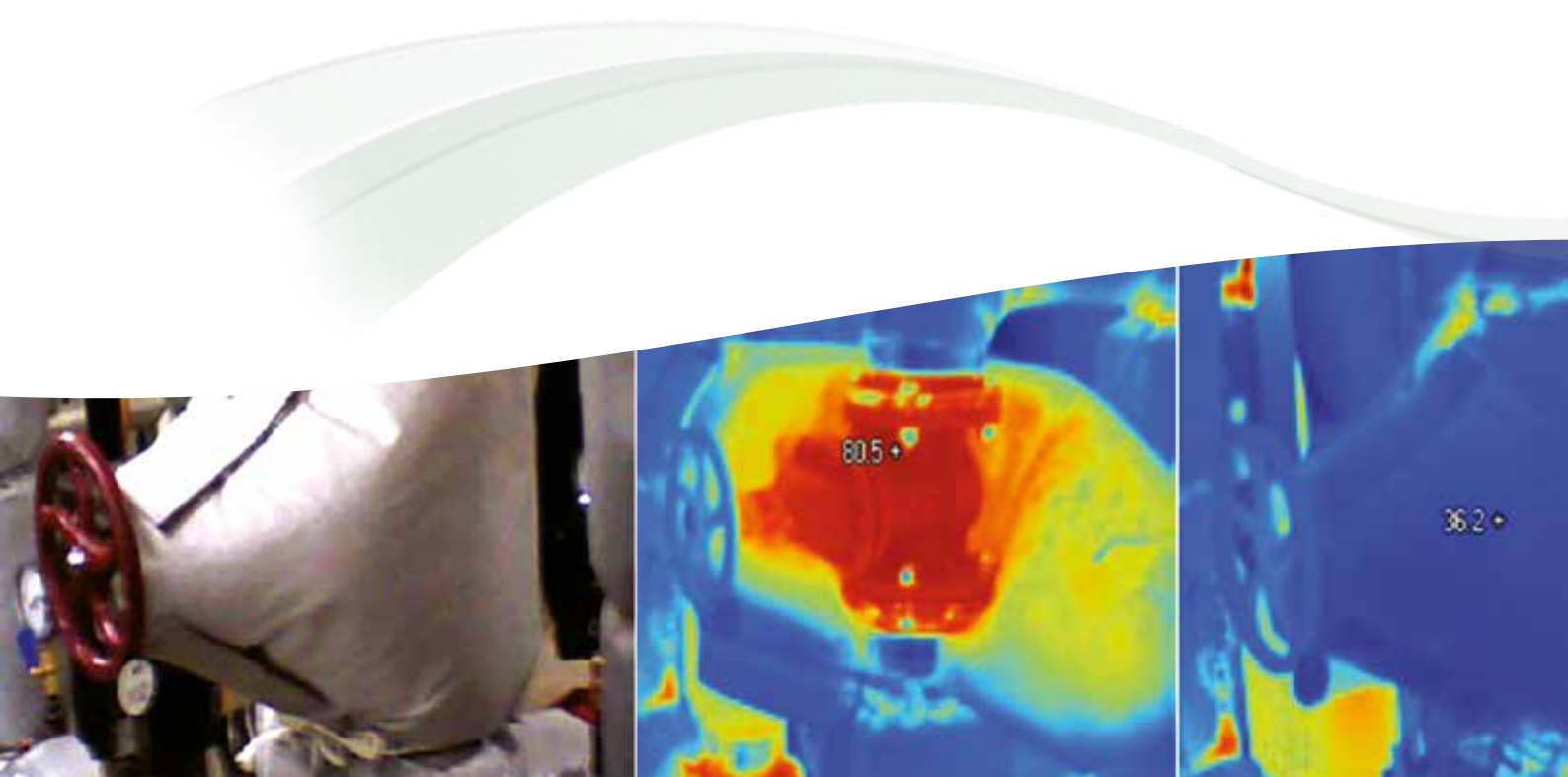



High Temperature Safety Surveys for Overheat Protection

Reducing the risk of scalding from overheated hot water

Valforce undertake a full survey of the existing high limit protection devices that are installed within your plant rooms.

Using the very latest test equipment we are able to independently test all of the leading manufacture's high limit protection valves and thermostats and prove they are tripping at the critical temperature set point.

Valforce would recommended an annual survey to be carried out by our skilled specialist team. This will ensure all equipment is working and proven to the recommended set point preventing the potential for dangerous situations occurring.

Introducing our safety survey into your planned maintenance programme gives you the peace of mind that you are protecting employees and visitors to the hospital against the potential hazards of scalding, whilst working towards your obligations as set out in HSE information sheet No 6.

Our High Temperature Safety Survey is part of a full range of products and services put together specifically to support the Hospitals and the NHS.

Implementing our safety survey into your planned maintenance programme gives you the peace of mind that you are protecting employees and visitors to the hospital against the potential hazards of scalding.

The benefits of a Valveforce Overheat Survey

What we deliver

- An overall appreciation of your heat exchange control equipment and recommendations
- Detailed inspection of the control system to ensure everything is installed and set up correctly
- Critical set point proving and testing using the latest calibrated test equipment
- Independent experienced steam and process valve specialist carrying out the survey
- Tested in accordance with the manufacturers guidelines and installation recommendations
- Labelling of each system with test date, together with a full and detailed report
- A test certificate as written proof of the survey together with the test criteria and results

Reasons to work with us

- Highlights potentially dangerous Health & Safety issues on site
- Meet your legal duties as set out in the Health & Safety guidelines No 6
- Non intrusive work so there is no interference with the hot water system
- Use our valve and steam systems experts to free up your own team
- All manufacturers protection devices can be surveyed, tested and reported on

Health Services Information Sheet No. 6

HSE managing the risks from hot water and surfaces in health and social care

The HSE document states the following:

- A risk assessment of the premises should be carried out to identify what controls are necessary and how the systems will be managed and maintained
- Controls to manage the risk from hot water or surfaces should be adequately maintained
- Maintenance schedules should take into account local conditions and the risk of valves failure

This information should be read in conjunction with the Health Technical Memorandum (HTM) 04 – 01
The control of legionella, hygiene, “safe” hot water cold water and drinking water.



Valveforce Ltd
Unit 20 Monkspath Business Park
Shirley
Solihull
B90 4NZ

 0121 711 1908

 0121 711 1909

 info@valveforce.co.uk

 www.valveforce.co.uk

part of The **force** Group
of Companies Ltd